

Reamers
Endmills
Drills
Countersinks/
Counterbores
Slitting Saws/
Cut-off tools
Cutters

SFM

スリワリフライス45径 ノンコート
Screw Slotting Cutters (45Dia.) non coat

SFMC

スリワリフライス45径 OK-Cコート
Screw Slotting Cutters (45Dia.) OK-C coat

製品略号 Product code	表面処理 Surface Treatment	切削条件 Cutting Conditions
SFM		
SFMC		



SFM

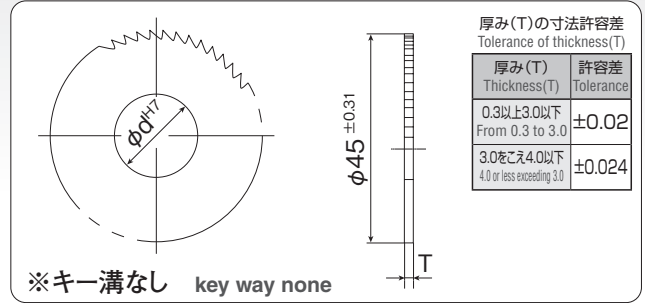

●小物の溝入れ用
For slitting small works

SFM ノンコート non coat		SFMC OK-Cコート OK-C coat		寸法 Size			
品番 Product No.	標準価格 Standard price ¥	品番 Product No.	標準価格 Standard price ¥	刃径 D	厚み T	穴径 d	刃数 NT
SFM003	3,000	SFMC003	4,200	45	0.3	15.875	90
SFM004	2,400	SFMC004	3,500	45	0.4	15.875	90
SFM005	2,100	SFMC005	2,900	45	0.5	15.875	90
SFM006	2,100	SFMC006	2,900	45	0.6	15.875	90
SFM007	2,100	SFMC007	2,900	45	0.7	15.875	90
SFM008	2,100	SFMC008	2,900	45	0.8	15.875	90
SFM009	2,100	SFMC009	2,900	45	0.9	15.875	90
SFM010	2,000	SFMC010	2,800	45	1.0	15.875	90
SFM011	2,000	SFMC011	2,900	45	1.1	15.875	90
SFM012	2,000	SFMC012	2,900	45	1.2	15.875	90
SFM013	2,000	SFMC013	2,900	45	1.3	15.875	90
SFM014	2,200	SFMC014	3,200	45	1.4	15.875	90
SFM015	2,200	SFMC015	3,200	45	1.5	15.875	90
SFM016	2,600	SFMC016	3,700	45	1.6	15.875	90
SFM017	2,600	SFMC017	3,700	45	1.7	15.875	90
SFM018	2,800	SFMC018	3,700	45	1.8	15.875	90
SFM019	2,800	SFMC019	3,700	45	1.9	15.875	90
SFM020	3,000	SFMC020	4,300	45	2.0	15.875	90
SFM021	3,000	SFMC021	4,300	45	2.1	15.875	90
SFM022	3,000	SFMC022	4,300	45	2.2	15.875	90
SFM023	3,000	SFMC023	4,300	45	2.3	15.875	90
SFM024	3,000	SFMC024	4,300	45	2.4	15.875	90
SFM025	3,000	SFMC025	4,300	45	2.5	15.875	90
SFM026	3,000	SFMC026	4,300	45	2.6	15.875	90
SFM027	3,200	SFMC027	4,300	45	2.7	15.875	90
SFM028	3,200	SFMC028	4,300	45	2.8	15.875	90
SFM029	3,200	SFMC029	4,300	45	2.9	15.875	90

スリワリフライスの側面振れ公差

Axial run-out tolerance of Screw Slotting Cutters

(単位 unit : mm)

外径(D) の区分 Dia. (mm)	側面の振れ Axial run-out						
	厚み(T)の区分 Thickness(T)						
	0.4以下 0.4 or less	0.4をこえ0.6以下 0.6 or less exceeding 0.4	0.6をこえ1.0以下 1.0 or less exceeding 0.6	1.0をこえ1.6以下 1.6 or less exceeding 1.0	1.6をこえ2.5以下 2.5 or less exceeding 1.6	2.5をこえ4.0以下 4.0 or less exceeding 2.5	4.0をこえ5.0以下 5.0 or less exceeding 4.0
45	0.16	0.12	0.1	0.08	0.06	0.05	—
70	—	0.16	0.12	0.1	0.08	0.06	0.05

SFM ノンコート non coat		SFMC OK-Cコート OK-C coat		寸法 Size			
品番 Product No.	標準価格 Standard price ¥	品番 Product No.	標準価格 Standard price ¥	刃径 D	厚み T	穴径 d	刃数 NT
SFM030	3,200	SFMC030	4,300	45	3.0	15.875	90
SFM031	3,300	SFMC031	4,500	45	3.1	15.875	90
SFM032	3,300	SFMC032	4,500	45	3.2	15.875	90
SFM033	3,300	SFMC033	4,500	45	3.3	15.875	90
SFM034	3,300	SFMC034	4,500	45	3.4	15.875	90
SFM035	3,300	SFMC035	4,500	45	3.5	15.875	90
SFM036	3,300	SFMC036	4,500	45	3.6	15.875	90
SFM037	4,400	SFMC037	6,100	45	3.7	15.875	90
SFM038	4,400	SFMC038	6,100	45	3.8	15.875	90
SFM039	4,400	SFMC039	6,100	45	3.9	15.875	90
SFM040	4,400	SFMC040	6,100	45	4.0	15.875	90

- リーマ
- エンドミル
- ドリル
- 面取り/座ぐり
- メタルソー
- カッター
- 切断用メタルソー
- 強力型メタルソー
- メタルソー
- スリワリフライス