

メタルソー Metal Slitting Saw

| series1

○メタルソー Metal Slitting Saw

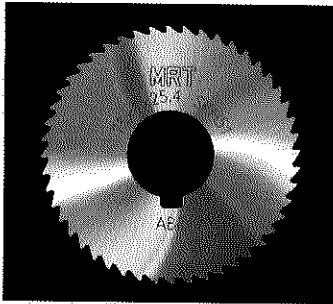

- 外径 (D) Outside diameter (D)
5mm ~ 200mm
- 厚み (t) Thickness (t)
0.1mm ~

主な用途 Use	切断用 ほか For cutting
補足 Others	穴径、刃数はご指定により製作いたします。両側面には刃先から中低勾配がつきます。厚み最低寸法は、外径寸法により変わりますので、事前にご確認下さい。 Bore diameter and the number of teeth are customizable upon order. For the double side face of cutter will be added back taper (side clearance) from outside to bore. The minimum thickness possible will change depending on the outside diameter. Please check to see if the combination is right for your needs upon ordering.

○スリワリフライス Screw Slotting Cutter

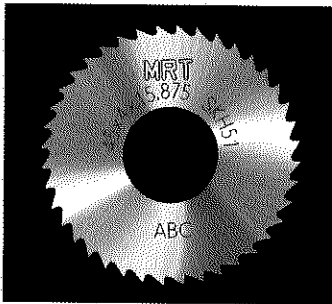

- 外径 (D) Outside diameter (D)
5mm ~ 200mm
- 厚み (t) Thickness (t)
0.1mm ~

主な用途 Use	切断用 ほか For cutting
補足 Others	穴径、刃数はご指定により製作いたします。両側面には刃先から中低勾配がつきます。厚み最低寸法は、外径寸法により変わりますので、事前にご確認下さい。 Bore diameter and the number of teeth are customizable upon order. For the double side face of cutter will be added back taper (side clearance) from outside to bore. The minimum thickness possible will change depending on the outside diameter. Please check to see if the combination is right for your needs upon ordering.

○共ボス付フライス Screw Slotting Cutter(with Boss/HUB)

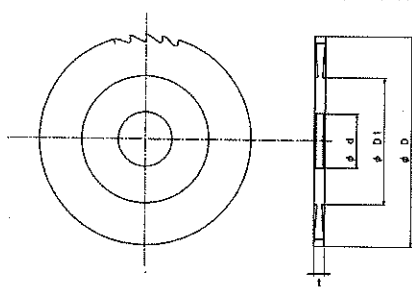
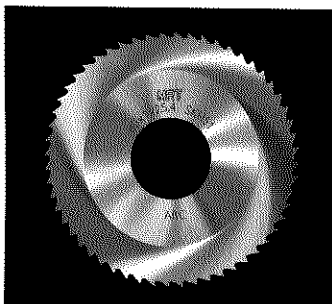

外径 (D) Outside diameter (D)	15mm ~ 200mm
厚み (t) Thickness (t)	0.15mm ~

主な用途 Use	アクチュエーター、電子部品 ほか Processing of electronic components such as actuators.
補足 Others	組合わせ等に使用。 Used in combination with other saws and/or separators.