



## **BIG DAISHOWA BIG-PLUS DUAL CONTACT**

*Not All Dual Contact Tooling is the Same!*

Important information inside about BIG-PLUS and manufacturers who claim to offer dual contact tooling systems.

# THE BIG-PLUS SPINDLE SYSTEM IS AN ORIGINAL DEVELOPMENT OF BIG DAISHOWA SEIKI CO., LTD.



## BIG-PLUS — The World's Most Rigid Dual Contact Spindle System

Adopted by more than 100 machine tool builders for over the past 20 years, thousands of machines and tens of thousands of BIG-PLUS tool holders are in operation today. Due to the popularity of BIG-PLUS, many tooling companies, without a proper license agreement, gauges, or manufacturing specifications & tolerances are offering dual contact tooling. The achievement of dual contact is only possible by strict control of flange face location to taper gauge line.

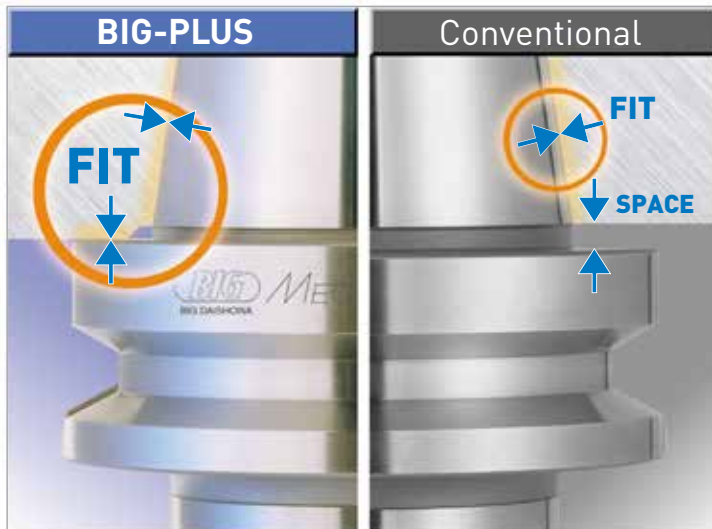

### Simultaneous Taper & Flange Fit

BIG-PLUS surpasses all other spindle concepts while offering interchangeability with existing machines and tool holders.

- Improved surface finish & dimensional accuracy
- Extended tool life
- Prevention of fretting corrosion caused by heavy cutting
- Improvement of ATC repeatability
- Elimination of Z-axial movement at high speeds
- Improved roundness of boring operations

### Basic Concept

The BIG-PLUS Spindle System is based on the most current available standards in ASME B5.50, JIS B6339 and DIN 69871. A conventional steep taper tool holder is supported on a reference diameter called the gauge line. On the contrary, a BIG-PLUS tool holder is supported on the flange face, which brings remarkable improvement to rigidity.

### Distance Between the Taper Gauge Line and Tool Flange is the Critical Dimension for BIG-PLUS

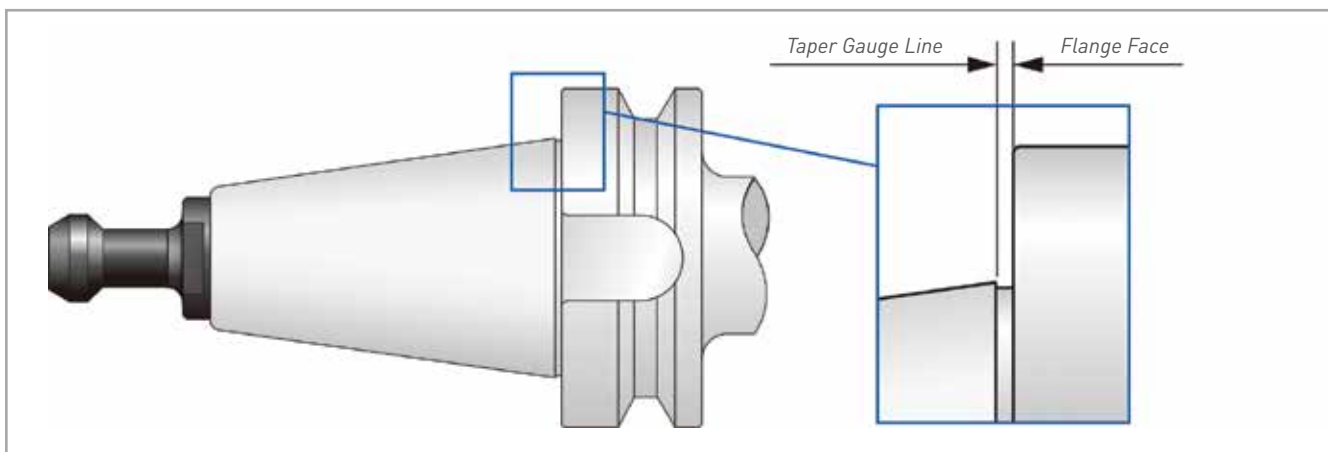

### BIG-PLUS Dual Contact Works on a Very Small Amount of Spindle Elastic Deformation

Taper contact before clamping is very important and therefore the dimension and tolerance for the flange face is extremely critical to achieving dual contact. There are 3 possible outcomes depending on the actual tool holder specification.

### The Current Market Contains Many Suppliers of Dual Contact Tooling Who Are NOT Licensed for BIG-PLUS

Without the license, they have neither the exclusive gauges nor dimensions and tolerances for the critical relationship of taper to flange. We acquired many of these tools from all regions of the world and inspected them with our gauges.

# THE BIG-PLUS SPINDLE SYSTEM IS AN ORIGINAL DEVELOPMENT OF BIG DAISHOWA SEIKI CO., LTD.



## Condition #1 Proper Fit

- Dual contact of taper and flange face after clamping

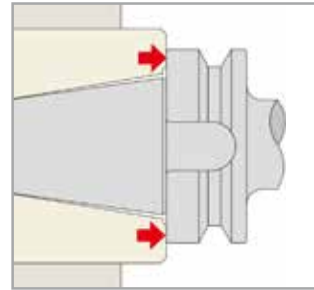
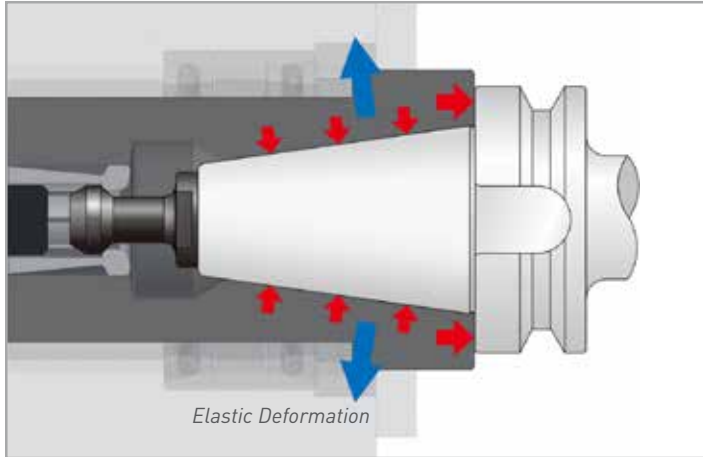

## Condition #2 Flange Contact Only Limited or No Taper Contact

- Poor runout accuracy
- Severe chatter and vibration
- Spindle damage

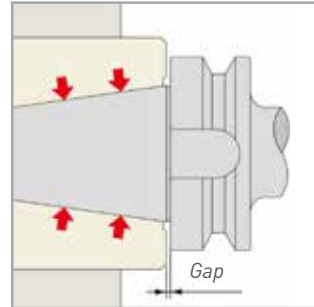

## Condition #3 Taper Contact Only No Flange Contact

- Features of BIG-PLUS are voided
- Works same as taper-only contact tooling

## Inspection Results of Sample Non-Licensed Dual Contact Tooling 25 Samples — 40 & 50 Taper “Dual Contact” Measured According to the BIG-PLUS Standard

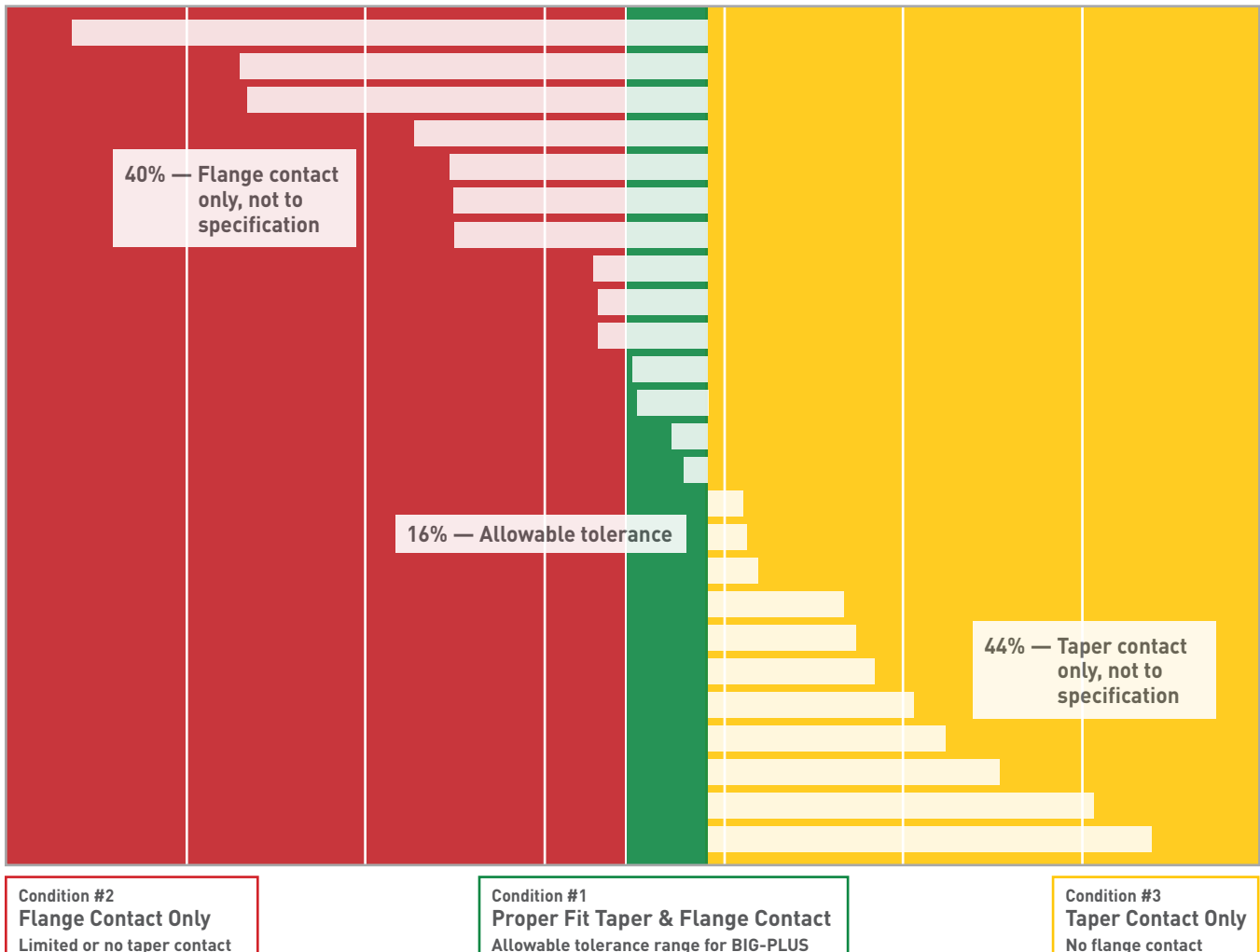

# BIG DAISHOWA Produces and Maintains All Spindle and Tool Holder BIG-PLUS Gauges World-Wide For Licensed Companies Only

## Strict Gauge Control

BIG-PLUS spindles produced by licensed machine tool or spindle builders are strictly controlled in dimensions by the BIG original Master Gauge. Only BIG-PLUS trademarked tool holders can achieve the optimal performance fully and safely.

## Gauges for Machine Spindle



Master Gauge



Measuring Device



Master Arbor

## BIG-PLUS Spindle System Machine Tool Builders

The BIG-PLUS Spindle System is offered by many of the world's leading manufacturers of machining centers. Some of the machine and spindle builders who have produced BIG-PLUS spindles are as follows:

ACCUWAY, **ADVANCED MACHINE**, ALEX-TECH, AMS, ANCA, AONO GIKEN, ARES, ASADA SEIKI, ASA TECH, AWEA, BERG SPANNTTECHNIK, BFW, BOST, BROTHER, CERI, CHEVALIER, CHUO-SEIKI, CITIZEN, COLGAR, D.S.TECHNOLOGIE, DAH LIH, DAITO, DAIYA SEIKI, DIXI, DMC, DMG MORI PRECISION BORING, DMG MORI SEIKI, DOOSAN, **DYNAMAX**, EGIN-HEINISCH, EGURO, EMCO, ENSHU, FADAL, ANUC, FEELER, FEMCO, FIRST, FIRST, **FISCHER**, FOREST-LINÉ, FPT, FRANZ KESSLER, GIDDINGS & LEWIS, GMN, GROB, **GTI**, HAIDE, HARDINGE, HARTFORD, HEYLIGENSTAEDT, HISION, HNK, HOMMA, HORKOS, HOWA, HSD, HST, HURCO, HWACHEON, IBAG, IBARMIA INNOVATEK, IKEGAI, INOUE KOSOKU KIKAI, JHENG TAI, JOBS, JOHNFORD, JTEKT MACHINE SYSTEMS, JTEKT, JUNGWOO M.S., JYOTI, KARATS, KASHIFUJI, KASWIN, KENTURN, KIRA, KITAMURA, KIWA, KMT, KOMATSU NTC, KONDIA, KOYO, KPTEC, LAZZATI, LMW, MAG, MAGNIX, MAKINO, MAKINO SEIKI, MANDELLI, MATSUURA, MAZAK, MCM, MECTRON, MILLTRONICS, MITSUI SEIKI, MOTOKUBO, MTE, MYL, N.S.S, NACHI, NAKAMURA, NEWAY, NICOLÁS CORREA, NIDEC MACHINE TOOL, NIDEC OKK, NIIGATA, NIPPON BEARING, NISHIJIMAX, NISSIN-MFG, NOMURA, **NORTHLAND TOOL**, NSK, NUMEN, O-M, OBATAKE, OHTORI, OKUMA, OMLAT, OMV, OVERMACH, PAMA, **PDS**, PIETRO CARNAGHI, PMC, QUASER, REIDEN, ROKU ROKU, ROYAL, RS TEC, SAJO, SEMA, SEMPUCO, **SETCO**, SHAN RONG, SHIBAURA, SHODA, SHW, SKF USA, SKG, SKODA, SKYNC, SMEC, SNK, SODICK, SORALUCE, SPINDER, SPINTEC, SPINTRUE, **SPS**, STARRAGHECKERT, STUDER, SUFENG, SUGINO, SUNWOO, **SUPERIOR SPINDLE SERVICE**, SWIFT, TAJMAC-ZPS, TAKAMAZ KIKAI KOUGYOU, TAKISAWA, TANABE, THETA, TONGTAI, TOS KURIM, TOS VARNSDORF, TOYO SEIKI, TSUDAKOMA, TSUGAMI, UGINT, UTSUNOMIYA, VICTOR TAICHUNG, VTEC, VYU CHENG, WALDRICH COBURG, WELE, WIA, YAMASAKI GIKEN, YAMASHINA SEIKI, YASDA, YASUNAGA, YCM, YU HUNG, ZAYER  
(As of April 2024)

• Bold company names are North American licensed BIG-PLUS spindle rebuilders

## BIG-PLUS Tooling Licensees

The following companies are licensed for production, sales, and use of the BIG-PLUS trademark:

BIG DAISHOWA INC

REGO-FIX

SUMITOMO

BIG KAISER PRECISION TOOLING LTD

YUKIWA SEIKO USA, INC

SANDVIK COROMANT

SHOWA TOOL CO, LTD

**Only Select BIG-PLUS Tooling from These Licensed Companies and ACCEPT NO IMITATIONS OR COPIES**

All products will be clearly marked with the following indications on all parts:

**BIG-PLUS Spindle System**

**License BIG Daishowa Seiki**

**BIG DAISHOWA Inc.**

2600 Huntington Blvd | Hoffman Estates, IL 60192 | P: (224) 770-2999 | F: (224) 770-2997 | bigdaishowa@us.bigdaishowa.com | bigdaishowa.com

04/2024 © Copyright 2024 BIG DAISHOWA Inc.