

超硬リーマ Hシリーズ H Series

商品コード : CH○○○○
Product Code

0.01mmとび
Increment

高精度加工対応 (+0.005)
刃径公差(Tolerance) (0)



Hシリーズの特長

Features of H Series

- ① 超硬ストレート刃と比較して切削速度が50%アップ可能です。
 - ② 深穴加工に最適……首下が長い
 - ③ 切粉前方排出抜群……左30°捻れ
- ① Reaming speed can be set 1.5 times faster than that of straight flute reamers.
 - ② Suitable for deep hole reaming due to its long body.
 - ③ Excellent downward chip flow due to its 30° left hand spiral flute.

Hシリーズの参考切削条件

Recommended Cutting Conditions

被削材 Workpiece	軟鋼 Mild Steels SS	炭素鋼 Carbon Steels S○○C	合金鋼 Alloy Steels SCM/SUJ	工具鋼 Tool Steels SKH/SKD	鋳鉄 Cast Iron FC/FCD	アルミニウム Aluminum A/ADC	銅・銅合金 Copper Alloys C	調質材 Quenched and tempered Steels ~40HRC
周速 (m/min) Cutting Speed	20~35	20~30	15~30	10~25	20~35	20~40	15~30	8~20

刃径 (mm) Diameter	1.0	3.0	6.0	8.0	10.0	12.0
送り速度 (mm/rev) Feed	0.01~0.025	0.05~0.1	0.05~0.1	0.08~0.25	0.1~0.3	0.15~0.35
リーマ代 (φ mm) Removal Amount	0.05~0.08	0.1	0.1~0.2	0.1~0.2	0.1~0.3	0.1~0.3

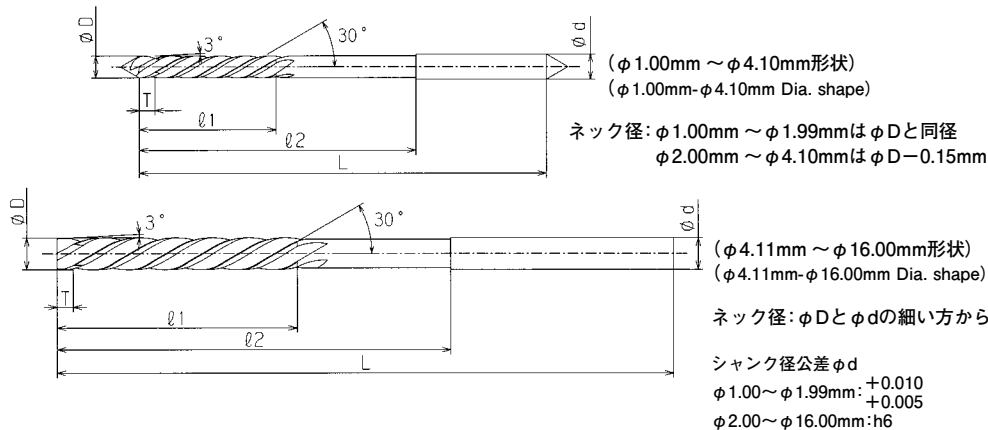

刃径φD Diameter	喰付長さT Chamfer Length
φ1.00～φ2.10	2.0mm
φ2.11～φ5.10	3.0mm
φ5.11～φ16.00	5.0mm

刃径公差 (+0.005)
(Tolerance) 0

0.01mmとび
Increment

単価:円 unit price: in JPY

型式・刃径φD Diameter (呼び寸法)	刃長ℓ1 Flute Length	全長L Overall Length	首下長ℓ2 Body Length	シャンク径φd Shank Diameter	刃数 Number of Flutes	標準定価 Retail Price	
						0.1mmとび Increment	0.01mmとび Increment
CH 1.00	8	46	15	1.0突出しセンタ	3	27,840	—
CH 1.01～1.49	10	〃	〃	1.5	4	27,840	33,410
CH 1.50	〃	〃	〃	〃	〃	18,580	—
CH 1.51～1.99	〃	〃	〃	2.0	〃	18,580	22,270
CH 2.00～2.10	〃	55	30	〃	〃	12,370	14,840
CH 2.11～2.60	15	60	35	2.5	〃	12,370	14,840
CH 2.61～3.10	〃	〃	〃	3.0	〃	12,370	14,840
CH 3.11～3.60	20	〃	〃	3.5	〃	12,370	14,840
CH 3.61～4.10	〃	〃	〃	4.0	〃	9,950	11,940
CH 4.11～4.60	〃	75	45	4.5穴センタ	〃	9,950	11,940
CH 4.61～5.10	〃	〃	〃	5.0	〃	9,950	11,940
CH 5.11～5.60	25	100	65	5.5	〃	9,950	11,940
CH 5.61～6.10	〃	〃	〃	6.0	〃	8,470	10,160
CH 6.11～6.60	〃	110	70	6.5	〃	8,470	10,160
CH 6.61～7.10	〃	〃	〃	7.0	〃	8,470	10,160
CH 7.11～7.60	30	125	85	7.5	〃	8,470	10,160
CH 7.61～8.10	〃	〃	〃	8.0	〃	10,220	12,260
CH 8.11～8.60	〃	135	90	8.5	〃	10,220	12,260
CH 8.61～9.10	〃	〃	〃	9.0	〃	11,720	14,060
CH 9.11～9.60	35	150	100	9.5	〃	11,720	14,060
CH 9.61～10.10	〃	〃	〃	10.0	〃	12,720	15,260
CH 10.11～10.60	〃	155	105	10.5	〃	16,450	19,740
CH 10.61～11.10	〃	〃	〃	11.0	〃	18,200	21,840
CH 11.11～11.60	〃	160	〃	11.5	〃	19,440	23,330
CH 11.61～12.10	〃	〃	〃	12.0	〃	19,440	23,330
CH 12.11～12.60	40	165	110	12.5	〃	20,700	24,840
CH 12.61～13.10	〃	〃	〃	13.0	〃	22,690	27,230
CH 13.11～13.60	〃	170	115	13.5	〃	26,920	32,300
CH 13.61～14.10	〃	〃	〃	14.0	6	29,170	35,000
CH 14.11～14.60	45	175	120	14.5	〃	31,900	38,280
CH 14.61～15.10	〃	〃	〃	15.0	〃	34,900	41,880
CH 15.11～15.60	〃	180	125	15.5	〃	39,140	46,970
CH 15.61～16.00	〃	〃	〃	16.0	〃	42,860	51,430

在庫一覧表(P.67～68) ※メーカー在庫(●)以外は、3本以上/1オーダーとさせていただきます。

Standard Inventory size list (P. 67～68) ※Apart from ●, it's available on made-to-order basis (Minimum Order Quantity: 3pcs/size)