

### 超硬リーマ Rシリーズ R Series

商品コード : CR〇.〇〇  
Product Code

0.01mmとび  
Increment



パープルコーティング  
「Purple Coating」  
登録商標 第4202221号  
Registered trademark

### Rシリーズの特長 Features of R Series

- ① 高硬度鋼用パープルコーティングと右リードの刃形状により、焼入れ硬度60HRC前後切削可能。
- ② シャンク径はエンドミルシャンクを採用。
- ① With our Japanese Trademark Registered "Purple Coating" and right hand spiral flute, quenched steel with hardness of approx. 60 HRC is machinable.
- ② Shank diameter is set according to JIS's (Japanese Industrial Standards) End Mill Shank Diameter standard.

### Rシリーズの参考切削条件 Recommended Cutting Conditions

被削材 Workpiece	調質材 Quenched and tempered Steels ~50HRC	調質材 Quenched and tempered Steels ~60HRC
周速 (m/min) Cutting Speed	9~18	6~12

刃径 (mm) Diameter	1.0	3.0	6.0	8.0	10.0	12.0
送り速度 (mm/rev) Feed	0.01~0.025	0.05~0.1	0.05~0.1	0.08~0.25	0.1~0.3	0.15~0.35
リーマ代 (φmm) Removal Amount	0.05	0.1	0.1	0.1	0.1	0.1

### Rシリーズの加工事例 Technical Data

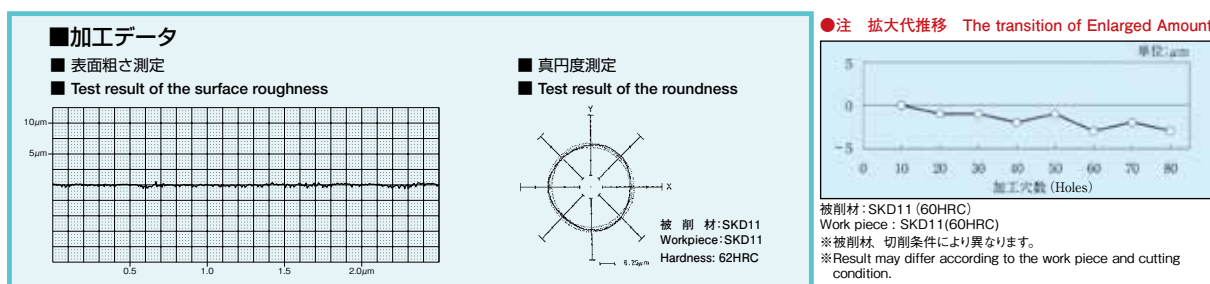

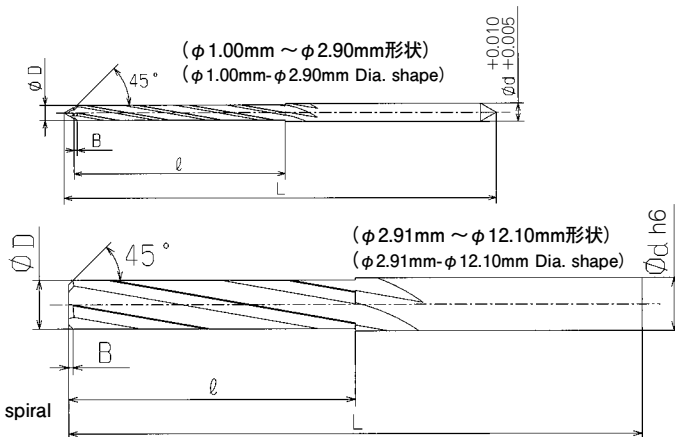

刃径φD Diameter	喰付長さB Chamfer Length (mm)
φ1.00~φ1.50	0.2mm
φ1.51~φ5.00	0.5mm
φ5.01~φ12.10	1.0mm

刃径公差 (+0.007)  
(Tolerance) 0

0.01mmとび  
Increment

単価:円 unit price: in JPY

型式・刃径φD Diameter (呼び寸法)	刃長ℓ Flute Length	全長L Overall Length	シャンク径φd Shank Diameter	刃数 Number of Flutes	標準定価 Retail Price	
					0.1mmとび Increment	0.01mmとび Increment
CR 1.00	15	50	1.0突出センタ	4	14,230	—
CR 1.01~1.50	〃	〃	1.5	〃	12,650	15,200
CR 1.51~1.99	25	60	2.0	〃	11,480	13,790
CR 2.00	〃	〃	〃	〃	10,440	—
CR 2.01~2.50	30	70	2.5	〃	9,880	11,860
CR 2.51~2.90	35	〃	3.0	〃	9,120	10,950
CR 2.91~3.00	40	80	3.0穴センタ	〃	7,580	10,950
CR 3.01~3.50	〃	〃	4.0	〃	8,620	10,360
CR 3.51~4.00	〃	〃	〃	〃	8,890	10,680
CR 4.01~4.50	〃	〃	6.0	〃	9,930	11,940
CR 4.51~5.00	〃	〃	〃	〃	10,650	12,780
CR 5.01~5.50	50	100	〃	〃	12,250	14,710
CR 5.51~6.00	〃	〃	〃	〃	12,750	15,300
CR 6.01~6.50	〃	〃	8.0	〃	14,860	17,840
CR 6.51~7.00	〃	〃	〃	〃	16,050	19,260
CR 7.01~7.50	〃	〃	〃	〃	19,620	23,560
CR 7.51~8.00	〃	〃	〃	〃	21,410	25,690
CR 8.01~8.50	60	115	10.0	〃	23,190	27,840
CR 8.51~9.00	〃	〃	〃	〃	28,840	34,610
CR 9.01~9.50	〃	〃	〃	〃	31,220	37,470
CR 9.51~10.00	〃	〃	〃	〃	32,410	38,890
CR 10.01~10.50	65	〃	12.0	〃	33,590	40,320
CR 10.51~11.00	〃	〃	〃	〃	34,190	41,040
CR 11.01~11.50	〃	130	〃	〃	35,670	42,810
CR 11.51~11.99	〃	〃	〃	〃	38,050	45,660
CR 12.00~12.10	〃	〃	〃	〃	38,050	50,230

在庫一覧表 (P.69~70) ※メーカー在庫(●)以外は、3本以上/1オーダーとさせていただきます。

Standard Inventory size list (P. 69~70) ※Apart from ●, it's available on made-to-order basis (Minimum Order Quantity: 3pcs/size)