

For HSK/BIG CAPTO SHANK KOMBI GRIP

- A unique clamping method using 2-way clutch needle rollers on the flange periphery. The tool can be safely fastened without damaging the taper.

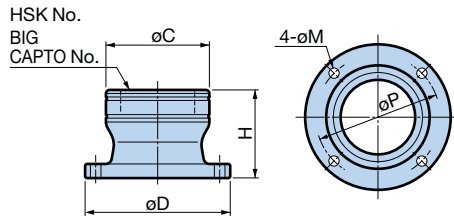

Model	HSK No.	BIG CAPTO No.	øC	øD	H	øP	øM
KG 25R	25	—	48	79	65	62	7 (for M6)
32R	32	C3※	55	85		69	
40R	40	C4※	63	93		77	
50R	50	C5※	75	105	70	89	9 (for M8)
63R	63	C6※	88	123.5	75	105.5	
80R	80	C8※	107	142	90	124	
100R	100	—	127	162	100	144	

1. BIG genuine BIG CAPTO C3 - C8 shanks only can be clamped.
2. Cap bolts (4 pcs) for mounting on a workbench or surface plate are not included.

Caution: Use after securely bolting to a workbench or surface plate.

For ST SHANK ST LOCK

- Fixes cylindrical shank tools, ideal for tightening nuts.
- Supports cylindrical shank diameters of ø20, ø25, and ø32.

Cylindrical Shank exclusive

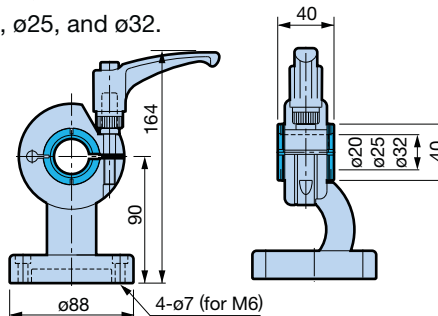

Model **STL40**

Also available for holders with small size interfaces including HSK-E25 and 32.

1. One sleeve each of ø20, ø25, and ø32 is included.
2. Do not clamp without a tool.
3. Cap bolts (4 pcs) for mounting on a workbench or surface plate are not included.

Caution: Use after securely bolting to a workbench or surface plate.

Tap Collet fastening jig TC MATE

- Easy tap mounting and removal for Tap Collets TC8, TC12, TC20, and TC30!

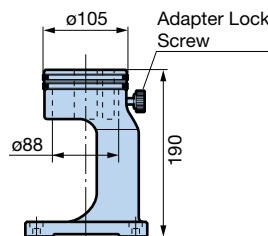

Model **TCM50**

1. One adapter is included with the body.
2. Adapter is also available separately.
3. Adapter Lock Screw is also available separately. (Model: **RTM0615**)
4. The body (blue component) is compatible with other Tooling Mates as long as the first 2 digits of the model number are identical.
5. Cap bolts (4 pcs) for mounting on a workbench or surface plate are not included.

Caution: Use after securely bolting to a workbench or surface plate.



Model **TCA50**

Exchangeable with existing adapter of your TMS50-□ Tooling Mate.