

# STEEL RING GAUGE LARGE SIZE



MTO product



HOWTO MOVE

Up to 520mm manufacturable. Custom size ring gauge is also available upon request.

## SUB-ZERO (Cryogenic hardened) TREATMENT STABILIZATION TREATMENT

■ Provided with aluminum case



### MATERIAL

- Alloy tool steel

### FEATURES

- Provided with inspection report

### ● DIMENSIONS

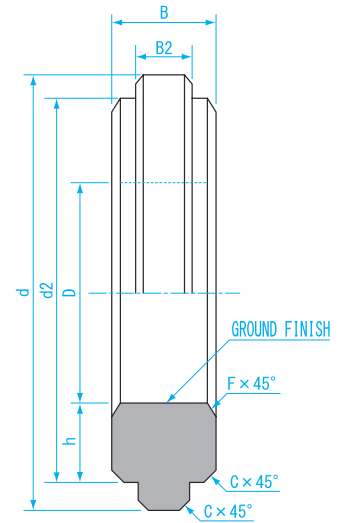

### SPECIFICATIONS

Size (mm)	Step (mm)	Out of Roundness (μm)	Diameter Inequality (μm)	Tolerance (μm)	Hardness (HV)
Over 200 to 230	5.0 step	5.0	10.0	± 7.0	653 } 772
Over 230 to 300	10.0 step			± 8.0	
Over 300 to 400				± 9.0	
Over 400 to 500				± 10.0	
Over 500 to 520					

- Surface roughness: Within Ra0.2μm
- Squareness: 0.1/φ450
- Parallelism: Within 0.025mm

### Size List

※ Reference value

Size D (mm)	Outside Diameter (mm)		Thickness (mm)		h (mm)	Chamfering for outside diameter C (mm)*	Chamfering for inside diameter F (mm)*	Remarks	Weight (kg)
	d	d2	B	B2					
Over 200 to 230	310	250~270	45	25	20	2.0	2.5	NOT Knurled	9~10
Over 230 to 260	340	280~300							11~14
Over 260 to 290	370	310~330							11~13
Over 290 to 320	400	340~360							12~14
Over 320 to 360	440	380~410	50	25	25	2.0	2.5	NOT Knurled	14~16
Over 360 to 400	480	420~450							15~18
Over 400 to 450	540	460~500							19~24
Over 450 to 500	600	510~550							23~29
Over 500 to 520	660	560~600							27~33

Order No.	Size (mm)
420500	205.0
421000	210.0
421500	215.0
422000	220.0
422500	225.0
423000	230.0
424000	240.0
425000	250.0
426000	260.0
427000	270.0
428000	280.0
429000	290.0
430000	300.0
431000	310.0
432000	320.0
433000	330.0
434000	340.0
435000	350.0

Order No.	Size (mm)
436000	360.0
437000	370.0
438000	380.0
439000	390.0
440000	400.0
441000	410.0
442000	420.0
443000	430.0
444000	440.0
445000	450.0
446000	460.0
447000	470.0
448000	480.0
449000	490.0
450000	500.0
451000	510.0
452000	520.0