

CMS
TCMS

切断用メタルソー ホモ処理品
Cold Circular Saws Homo Treatment

切断用メタルソー TiNコーティング
Cold Circular Saw TiN coated

品番例 Example of product number	T	CMS	01	-P03
	製品番号 Product code	製品No. Product number	ピッチ Pitch	
	表示なし=丸刃品 Pitch sign none=teethless			
	TCMS=TiN処理品・P□=ピッチ□品 TCMS=TiN coated P□=with tooth pitch			

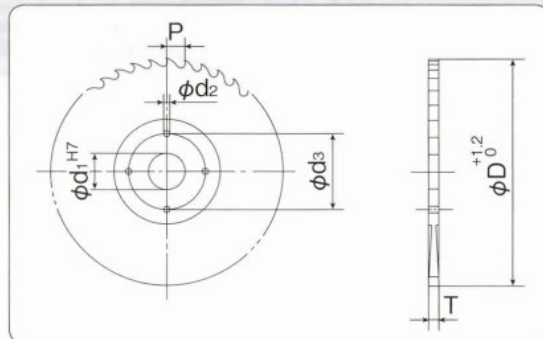
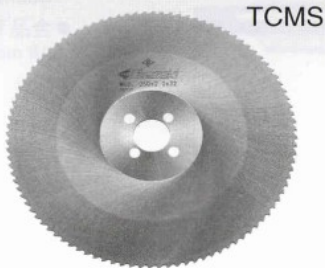
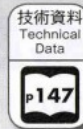

●切断加工用
For cutting process

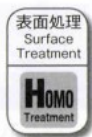

※の製品は生産終了につき在庫限りとなります。

コードNo. Code No.	寸法 Size				CMS Homo処理品		TCMS TiN処理品		機械メーカー名 Adaptive machine
	刃径 D	厚み T	穴径 d1	ピンホール (d3)×(d2)× (個数)	品番 Product No.	刃切品標準価格 (丸刃品標準価格) With tooth (teethless) ¥	品番 Product No.	刃切品標準価格 (丸刃品標準価格) With tooth (teethless) ¥	
01	250	1.5	32	45×8.5×2 50×9.0×2	※CMS01	23,800 (21,500)	※TCMS01	26,200 (23,700)	高速(KOSOKU)KCM10,250ミタチ (MITACHI) MMC-250,津根(TSUNE) ロビープロマックス, 日立工機(HITACHI)CU-10
02	250	2.0	32	45×8.5×2 50×9.0×2	CMS02	19,000 (17,100)	※TCMS02	22,800 (20,600)	
03	250	2.0	32	63×11×4	※CMS03	23,800 (21,500)	※TCMS03	26,200 (23,700)	アマダ(AMADA)CM400,中野(NAKANO) IBP,昭和(SHOWA)MS250
04	280	2.0	32	50×9×4	※CMS04	29,100 (26,200)	※TCMS04	32,100 (28,800)	津根(TSUNE)エコノミーワグナー
05		2.5			※CMS05	30,400 (27,400)	※TCMS05	33,500 (30,200)	
06	280	2.0	32	63×11×4	※CMS06	29,100 (26,200)	※TCMS06	32,100 (28,800)	アマダ(AMADA)CM400, 中野(NAKANO)IBP
07	280	2.5	32	63×11×4	CMS07	27,900 (25,100)	※TCMS07	33,500 (30,200)	
08	280	2.0	40	55×9×2 65×12×2	※CMS08	29,100 (26,200)	※TCMS08	32,100 (28,800)	藤田機械(FUJITA)・ 大野鋼機(OHNO)アイゼルフォーカス
09		2.5			※CMS09	30,400 (27,400)	※TCMS09	33,500 (30,200)	
10	300	1.5	31.8	50×9×2	※CMS10	34,400 (31,000)	※TCMS10	37,800 (34,100)	
11	300	2.0	31.8	50×9×2	CMS11	27,300 (24,700)	※TCMS11	32,800 (29,700)	大同興業(DAIDO)プリマックス300
12		2.5			CMS12	29,400 (26,600)	※TCMS12	35,300 (32,000)	
13	300	2.0	32	50×9×2	※CMS13	34,400 (31,000)	※TCMS13	37,800 (34,100)	マックエンゼル(MAC)300, 日東工機(NITTO)NTC-300
14		2.5			※CMS14	37,000 (33,400)	※TCMS14	40,700 (36,800)	
15	300	2.0	32	63×11×4	CMS15	31,500 (28,400)	※TCMS15	37,800 (34,100)	中野(NAKANO)IBP
16	300	2.5	32	63×11×4	※CMS16	37,000 (33,400)	※TCMS16	40,700 (36,800)	
17	300	2.0	40	63×11×4	CMS17	31,500 (28,400)	※TCMS17	37,800 (34,100)	村橋(MURAHASHI)SSグレート キャプテンソーV-100
18		2.5			CMS18	29,400 (26,600)	※TCMS18	35,300 (32,000)	
19	315	2.0	32	63×11×4	※CMS19	39,600 (35,700)	※TCMS19	43,600 (39,300)	津根(TSUNE)エコノミーワグナー, 日立工機(HITACHI)CU-13, アマダ(AMADA)CM400,昭和(SHOWA) MS350
20	315	2.5	32	63×11×4	CMS20	31,600 (28,400)	※TCMS20	38,000 (34,100)	
21	315	3.0	32	63×11×4	※CMS21	42,300 (38,100)	※TCMS21	46,600 (41,900)	
22	315	2.5	40	63×11×4	※CMS22	39,600 (35,700)	※TCMS22	43,600 (39,300)	村橋(MURAHASHI)SSグレート キャプテンソーV-100
23		3.0			※CMS23	42,300 (38,100)	※TCMS23	46,600 (41,900)	