

FMA/TFMA FMB/TFMB

スリワリフライス70径(56枚刃) ノン・コーティング/TiNコーティング
Screw Slotting Cutters 70Dia. (56NT) Non-coated/TiN-coated

スリワリフライス70径(72枚刃) ノン・コーティング/TiNコーティング
Screw Slotting Cutters 70Dia. (72NT) Non-coated/TiN-coated

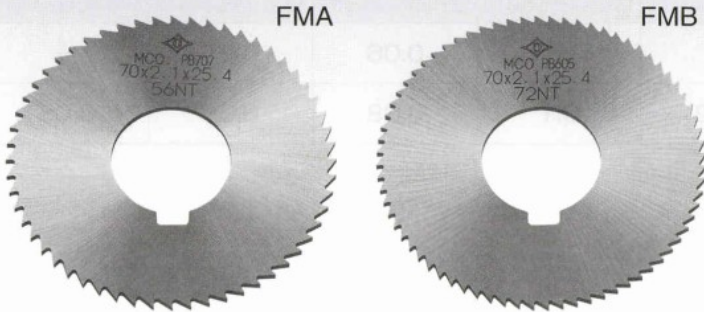

●溝入れ加工用
For slitting process

製品略号 Product code	表面処理 Surface Treatment	切削条件 Cutting Conditions
FMA		
TFMA	TiN Coat	
FMB		
TFMB	TiN Coat	

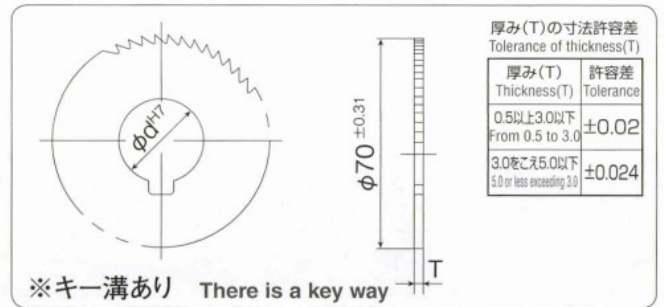

	A=56枚刃				B=72枚刃				寸法 Size		
	FMA ノン・コーティング		TFMA TiNコーティング		FMB ノン・コーティング		TFMB TiNコーティング				
	品番 Product No.	標準価格 Standard price ¥	品番 Product No.	標準価格 Standard price ¥	品番 Product No.	標準価格 Standard price ¥	品番 Product No.	標準価格 Standard price ¥	刃径 D	厚み T	穴径 d
	FMA005	3,800	TFMA005	5,200	FMB005	3,800	TFMB005	5,200	70	0.5	25.4
	FMA006	3,500	TFMA006	5,000	FMB006	3,500	TFMB006	5,000	70	0.6	25.4
	FMA007	3,400	TFMA007	4,800	FMB007	3,400	TFMB007	4,800	70	0.7	25.4
	FMA008	3,400	TFMA008	4,800	FMB008	3,400	TFMB008	4,800	70	0.8	25.4
	FMA009	3,400	TFMA009	4,800	FMB009	3,400	TFMB009	4,800	70	0.9	25.4
	FMA010	3,300	TFMA010	4,600	FMB010	3,300	TFMB010	4,600	70	1.0	25.4
	FMA011	3,400	TFMA011	4,800	FMB011	3,400	TFMB011	4,800	70	1.1	25.4
	FMA012	3,400	TFMA012	4,800	FMB012	3,400	TFMB012	4,800	70	1.2	25.4
	FMA013	3,400	TFMA013	4,800	FMB013	3,400	TFMB013	4,800	70	1.3	25.4
	FMA014	3,600	TFMA014	5,000	FMB014	3,600	TFMB014	5,000	70	1.4	25.4
	FMA015	3,600	TFMA015	5,000	FMB015	3,600	TFMB015	5,000	70	1.5	25.4
	FMA016	3,700	TFMA016	5,300	FMB016	3,700	TFMB016	5,300	70	1.6	25.4
	FMA017	3,700	TFMA017	5,300	FMB017	3,700	TFMB017	5,300	70	1.7	25.4
	FMA018	3,800	TFMA018	5,600	FMB018	3,800	TFMB018	5,600	70	1.8	25.4
	FMA019	3,800	TFMA019	5,600	FMB019	3,800	TFMB019	5,600	70	1.9	25.4
	FMA020	3,800	TFMA020	5,600	FMB020	3,800	TFMB020	5,600	70	2.0	25.4
	FMA021	3,800	TFMA021	5,600	FMB021	3,800	TFMB021	5,600	70	2.1	25.4
	FMA022	3,800	TFMA022	5,600	FMB022	3,800	TFMB022	5,600	70	2.2	25.4
	FMA023	4,200	TFMA023	5,800	FMB023	4,200	TFMB023	5,800	70	2.3	25.4
	FMA024	4,200	TFMA024	5,800	FMB024	4,200	TFMB024	5,800	70	2.4	25.4
	FMA025	4,200	TFMA025	5,800	FMB025	4,200	TFMB025	5,800	70	2.5	25.4
	FMA026	4,200	TFMA026	5,800	FMB026	4,200	TFMB026	5,800	70	2.6	25.4
	FMA027	4,300	TFMA027	6,000	FMB027	4,300	TFMB027	6,000	70	2.7	25.4
	FMA028	4,300	TFMA028	6,000	FMB028	4,300	TFMB028	6,000	70	2.8	25.4
	FMA029	4,300	TFMA029	6,000	FMB029	4,300	TFMB029	6,000	70	2.9	25.4

スリワリフライスの側面振れ公差
Axial run-out tolerance of Screw Sloting Cutters

(単位 unit : mm)

外径(D) の区分 Dia. (mm)	側面の振れ Axial run-out						
	厚み(T)の区分 Thickness(T)						
	0.4以下 0.4 or less	0.4をこえ0.6以下 0.6 or less exceeding 0.4	0.6をこえ1.0以下 1.0 or less exceeding 0.6	1.0をこえ1.6以下 1.6 or less exceeding 1.0	1.6をこえ2.5以下 2.5 or less exceeding 1.6	2.5をこえ4.0以下 4.0 or less exceeding 2.5	4.0をこえ5.0以下 5.0 or less exceeding 4.0
45	0.16	0.12	0.1	0.08	0.06	0.05	—
70	—	0.16	0.12	0.1	0.08	0.06	0.05

リーマ

エンドミル

ドリル

面取り/
座ぐり

メタルソー

カッター

A=56枚刃				B=72枚刃				寸法 Size		
FMA	ノン・コーティング	TFMA	TiNコーティング	FMB	ノン・コーティング	TFMB	TiNコーティング			
品番 Product No.	標準価格 Standard price ¥	品番 Product No.	標準価格 Standard price ¥	品番 Product No.	標準価格 Standard price ¥	品番 Product No.	標準価格 Standard price ¥	刃径 D	厚み T	穴径 d
FMA030	4,300	TFMA030	6,000	FMB030	4,300	TFMB030	6,000	70	3.0	25.4
FMA031	4,400	TFMA031	6,100	FMB031	4,400	TFMB031	6,100	70	3.1	25.4
FMA032	4,400	TFMA032	6,100	FMB032	4,400	TFMB032	6,100	70	3.2	25.4
FMA033	4,400	TFMA033	6,100	FMB033	4,400	TFMB033	6,100	70	3.3	25.4
FMA034	4,400	TFMA034	6,100	FMB034	4,400	TFMB034	6,100	70	3.4	25.4
FMA035	4,400	TFMA035	6,100	FMB035	4,400	TFMB035	6,100	70	3.5	25.4
FMA036	4,400	TFMA036	6,100	FMB036	4,400	TFMB036	6,100	70	3.6	25.4
FMA037	4,400	TFMA037	6,100	FMB037	4,400	TFMB037	6,100	70	3.7	25.4
FMA038	4,800	TFMA038	6,700	FMB038	4,800	TFMB038	6,700	70	3.8	25.4
FMA039	4,800	TFMA039	6,700	FMB039	4,800	TFMB039	6,700	70	3.9	25.4
FMA040	4,800	TFMA040	6,700	FMB040	4,800	TFMB040	6,700	70	4.0	25.4
FMA041	4,800	TFMA041	6,700	FMB041	4,800	TFMB041	6,700	70	4.1	25.4
FMA042	4,800	TFMA042	6,700	FMB042	4,800	TFMB042	6,700	70	4.2	25.4
FMA043	4,800	TFMA043	6,700	FMB043	4,800	TFMB043	6,700	70	4.3	25.4
FMA044	5,100	TFMA044	7,200	FMB044	5,100	TFMB044	7,200	70	4.4	25.4
FMA045	5,100	TFMA045	7,200	FMB045	5,100	TFMB045	7,200	70	4.5	25.4
FMA046	5,100	TFMA046	7,200	FMB046	5,100	TFMB046	7,200	70	4.6	25.4
FMA047	5,100	TFMA047	7,200	FMB047	5,100	TFMB047	7,200	70	4.7	25.4
FMA048	5,100	TFMA048	7,200	FMB048	5,100	TFMB048	7,200	70	4.8	25.4
FMA049	5,100	TFMA049	7,200	FMB049	5,100	TFMB049	7,200	70	4.9	25.4
FMA050	5,100	TFMA050	7,200	FMB050	5,100	TFMB050	7,200	70	5.0	25.4

切断用
メタルソー

強力型
メタルソー

メタルソー

スリワリフライス