

# THREAD PIN GAUGE

Enables easy threaded hole centering and locating

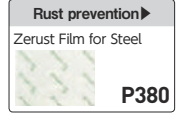

HOW TO MOVE



## FEATURES

- Easy handling with simple tool
- Enables to indicate the center of threaded hole
- More accurate, economical and easier than other gauges
- Made with stainless steel, prevents the thread pin gauge from rust
- Tapered bottom of the measurement area secures fit with work and allows high accuracy measurement



## DIMENSIONS

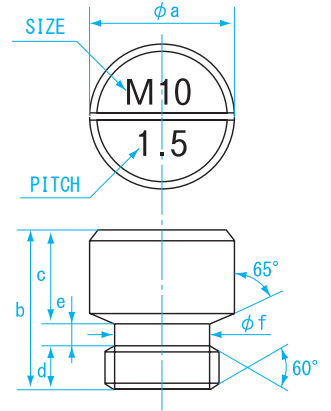

Accuracy	Runout between Measuring Head and Screw: Below 0.01mm Accuracy of Measuring Head (size: a): Below ±0.005mm Screw: equivalent for JIS for the second grade
Material	Stainless steel (SUS303)

## <Size List>

Order No.	Model No.	Size	a (mm)	b (mm)	c (mm)	d (mm)	e (mm)	f (mm)
360204	THP-0204	M 2 × P0.4	4				0.5	1.44
360305	THP-0305	M 3 × P0.5	5	9.5		3		2.30
360407	THP-0407	M 4 × P0.7	6		6	4.3	0.7	3.02
360508	THP-0508	M 5 × P0.8	7	11				3.88
360607	THP-06075	M 6 × P0.75	8	14	8	5	1	4.95
360610	THP-0610	M 6 × P1.0						4.60
360810	THP-0810	M 8 × P1.0	10	17		5.5		6.60
360812	THP-08125	M 8 × P1.25						6.25
361010	THP-1010	M10 × P1.0						8.60
361012	THP-10125	M10 × P1.25	12	18		6.5		8.25
361015	THP-1015	M10 × P1.5						7.90
361210	THP-1210	M12 × P1.0						10.60
361212	THP-12125	M12 × P1.25	14	19		7.5	1.5	10.25
361215	THP-1215	M12 × P1.5			10			9.90
361217	THP-12175	M12 × P1.75						9.55
361415	THP-1415	M14 × P1.5	16					11.90
361420	THP-1420	M14 × P2.0						11.20
361615	THP-1615	M16 × P1.5	18	20		8.5		13.90
361620	THP-1620	M16 × P2.0						13.20
361825	THP-1825	M18 × P2.5	20					14.50
362025	THP-2025	M20 × P2.5	22					16.50

※ Custom made Pin Gauge is also available

## How to use Thread Pin Gauge

- Easily locate threaded hole position with thread pin gauge  
CMM can easily attain the hole center using thread pin gauge

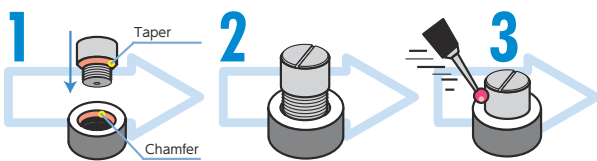

1. Prepare a thread pin gauge the same size as the threaded hole
2. Hand screw the thread pin gauge into the threaded hole
3. Measure!



HOW TO MOVE

## Example of use

- Reference position established with two threaded holes
- Pitch measurement between threaded holes

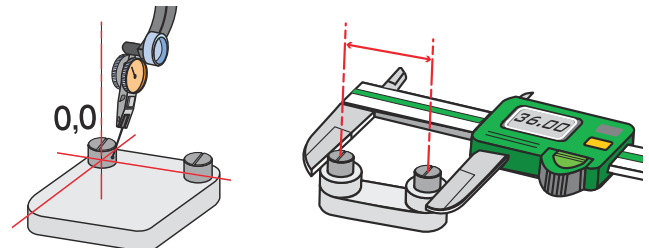

HOW TO MOVE



BLOCK GAUGE

PIN GAUGE

PIN VISE

PIN GAUGE ACCESSORIES

RING GAUGE

PLUG GAUGE

LIMIT GAUGE

THICKNESS GAUGE

TAPER GAUGE

WELDING GAUGE

OTHER GAUGES