

Reamers

Endmills

Drills

Countersinks/
Counterbores

Slitting Saws/
Cut-off tools

Cutters

Cold Circular
Saws

High Power
Slitting Saws

Metal Slitting
Saws

Screw Slotting
Cutters

MS
TMS

メタルソー ノン・コーティング
Metal Slitting Saws Non-coated

メタルソー TiNコーティング
Metal Slitting Saws TiN coated

製品略号 Product code	表面処理 Surface Treatment	切削条件 Cutting Conditions
MS		
TMS		

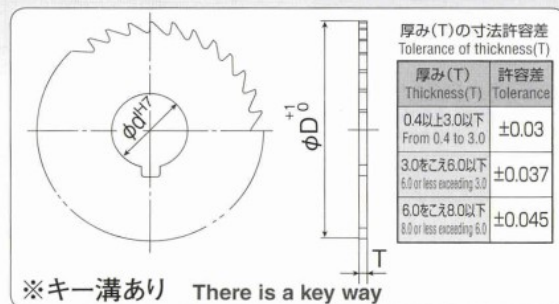

- 金属の溝入れ加工
For slitting work in metals
- 精密切断加工
For precision cutting work

穴径φ25.4 Hole Dia. φ25.4

MS ノン・コーティング		TMS TiNコーティング		寸法 Size			
品番 Product No.	標準価格 Standard price ¥	品番 Product No.	標準価格 Standard price ¥	刃径 D	厚み T	穴径 d	刃数 NT
MST075X004	5,000	TMST075X004	7,100	75	0.4	25.4	48
MST075X005	5,000	TMST075X005	7,100	75	0.5	25.4	48
MST075X006	4,400	TMST075X006	6,000	75	0.6	25.4	48
MST075X007	4,400	TMST075X007	6,000	75	0.7	25.4	48
MST075X008	4,400	TMST075X008	6,000	75	0.8	25.4	48
MST075X009	4,400	TMST075X009	6,000	75	0.9	25.4	48
MST075X010	4,000	TMST075X010	5,500	75	1.0	25.4	48
MST075X011	4,100	TMST075X011	5,700	75	1.1	25.4	48
MST075X012	4,100	TMST075X012	5,700	75	1.2	25.4	48
MST075X013	4,100	TMST075X013	5,700	75	1.3	25.4	48
MST075X014	4,100	TMST075X014	5,700	75	1.4	25.4	48
MST075X015	4,100	TMST075X015	5,700	75	1.5	25.4	40
MST075X016	4,100	TMST075X016	5,800	75	1.6	25.4	40
MST075X017	4,100	TMST075X017	5,800	75	1.7	25.4	40
MST075X018	4,100	TMST075X018	5,800	75	1.8	25.4	40
MST075X019	4,100	TMST075X019	5,800	75	1.9	25.4	40
MST075X020	4,100	TMST075X020	5,800	75	2.0	25.4	40
MST075X021	4,700	TMST075X021	6,500	75	2.1	25.4	40
MST075X022	4,700	TMST075X022	6,500	75	2.2	25.4	40
MST075X023	4,700	TMST075X023	6,500	75	2.3	25.4	40
MST075X024	4,700	TMST075X024	6,500	75	2.4	25.4	40
MST075X025	4,700	TMST075X025	6,500	75	2.5	25.4	40
MST075X026	4,900	TMST075X026	6,900	75	2.6	25.4	40
MST075X027	4,900	TMST075X027	6,900	75	2.7	25.4	40
MST075X028	4,900	TMST075X028	6,900	75	2.8	25.4	40
MST075X029	4,900	TMST075X029	6,900	75	2.9	25.4	40
MST075X030	4,900	TMST075X030	6,900	75	3.0	25.4	40
MST075X031	5,200	TMST075X031	7,300	75	3.1	25.4	40
MST075X032	5,200	TMST075X032	7,300	75	3.2	25.4	40
MST075X033	5,200	TMST075X033	7,300	75	3.3	25.4	40
MST075X034	5,200	TMST075X034	7,300	75	3.4	25.4	40

メタルソーの側面振れ公差

Axial run-out of tolerance Metal Slitting Saws

外径(D) の区分 Dia. (mm)	側面の振れ Axial run-out							
	厚み(T)の区分 Thickness(T)							
	0.4以下 0.4 or less	0.4をこえ0.6以下 0.6 or less exceeding 0.4	0.6をこえ1.0以下 1.0 or less exceeding 0.6	1.0をこえ1.6以下 1.6 or less exceeding 1.0	1.6をこえ2.5以下 2.5 or less exceeding 1.6	2.5をこえ4.0以下 4.0 or less exceeding 2.5	4.0をこえ6.0以下 6.0 or less exceeding 4.0	6.0をこえ8.0以下 8.0 or less exceeding 6.0
75	0.2	0.16	0.12	0.11	0.08	0.06	0.05	0.04
100,125	—	0.20	0.16	0.12	0.1	0.08	0.06	0.05
150,175,200	—	—	0.2	0.16	0.12	0.1	0.08	0.06
250	—	—	—	—	0.16	0.12	0.1	0.08

MS ノン・コーティング		TMS TiNコーティング		寸法 Size			
品番 Product No.	標準価格 Standard price ¥	品番 Product No.	標準価格 Standard price ¥	刃径 D	厚み T	穴径 d	刃数 NT
MST075X035	5,200	TMST075X035	7,300	75	3.5	25.4	36
MST075X036	5,500	TMST075X036	7,900	75	3.6	25.4	36
MST075X037	5,500	TMST075X037	7,900	75	3.7	25.4	36
MST075X038	5,500	TMST075X038	7,900	75	3.8	25.4	36
MST075X039	5,500	TMST075X039	7,900	75	3.9	25.4	36
MST075X040	5,500	TMST075X040	7,900	75	4.0	25.4	36
MST075X041	6,000	TMST075X041	8,400	75	4.1	25.4	36
MST075X042	6,000	TMST075X042	8,400	75	4.2	25.4	36
MST075X043	6,000	TMST075X043	8,400	75	4.3	25.4	36
MST075X044	6,000	TMST075X044	8,400	75	4.4	25.4	36
MST075X045	6,000	TMST075X045	8,400	75	4.5	25.4	36
MST075X046	6,100	TMST075X046	8,700	75	4.6	25.4	36
MST075X047	6,100	TMST075X047	8,700	75	4.7	25.4	36
MST075X048	6,100	TMST075X048	8,700	75	4.8	25.4	36
MST075X049	6,100	TMST075X049	8,700	75	4.9	25.4	36
MST075X050	6,100	TMST075X050	8,700	75	5.0	25.4	36
MST075X055	7,500	TMST075X055	10,600	75	5.5	25.4	36
MST075X060	7,500	TMST075X060	10,600	75	6.0	25.4	36
MST075X065	8,800	TMST075X065	12,500	75	6.5	25.4	36
MST075X070	8,800	TMST075X070	12,500	75	7.0	25.4	36
MST075X075	10,200	TMST075X075	14,300	75	7.5	25.4	36
MST075X080	10,200	TMST075X080	14,300	75	8.0	25.4	36
MST100X005	8,700	TMST100X005	12,400	100	0.5	25.4	56
MST100X006	7,200	TMST100X006	10,200	100	0.6	25.4	56
MST100X007	7,200	TMST100X007	10,200	100	0.7	25.4	56
MST100X008	7,200	TMST100X008	10,200	100	0.8	25.4	56
MST100X009	7,200	TMST100X009	10,200	100	0.9	25.4	56
MST100X010	6,600	TMST100X010	9,400	100	1.0	25.4	56
MST100X011	6,800	TMST100X011	9,500	100	1.1	25.4	56
MST100X012	6,800	TMST100X012	9,500	100	1.2	25.4	56
MST100X013	6,800	TMST100X013	9,500	100	1.3	25.4	56
MST100X014	6,800	TMST100X014	9,500	100	1.4	25.4	56
MST100X015	6,800	TMST100X015	9,500	100	1.5	25.4	56
MST100X016	6,800	TMST100X016	9,500	100	1.6	25.4	56
MST100X017	6,800	TMST100X017	9,500	100	1.7	25.4	56
MST100X018	6,800	TMST100X018	9,500	100	1.8	25.4	56
MST100X019	6,800	TMST100X019	9,500	100	1.9	25.4	56
MST100X020	6,800	TMST100X020	9,500	100	2.0	25.4	56
MST100X021	7,200	TMST100X021	10,300	100	2.1	25.4	56

リーマ

エンドミル

ドリル

面取り/
座ぐり

メタルソー

カッター

切断用
メタルソー

強力型
メタルソー

メタルソー

スリワフライス