

## TOOLING MATE UNIVERSAL

- With flexible positions of vertical, horizontal and diagonal, tool setup time is drastically reduced.

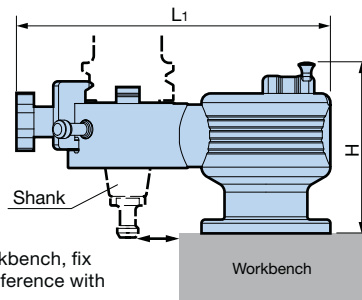

When mounting on a workbench, fix at a location without interference with the pullstud bolt.

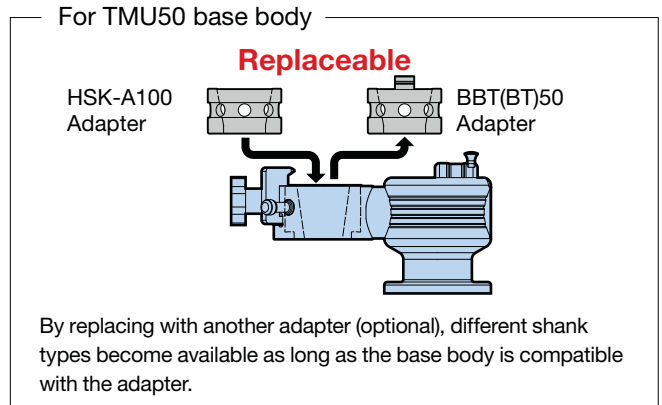
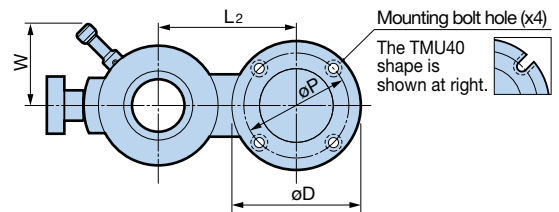

Model	Shank	L <sub>1</sub>	L <sub>2</sub>	øD	H	W	Mounting Bolt Hole		Weight (kg)	Adapter Model
							øP	Size		
<b>TMU40-40</b>	BT40 , BBT40	232	105	98	135	69	80	M8	6.9	TMUA40-40
<b>-HSK 63</b>	HSK-A63								6.8	-HSK63
<b>TMU50-50</b>	BT50 , BBT50	340	150	140	185	89	114	M10	19.7	TMUA50-50
<b>-HSK100</b>	HSK-A100								19.1	-HSK100

1. One adapter is included with the body.
2. The weight does not include the adapter.
3. Adapter is also available separately.
4. Cap bolts (4 pcs) for mounting on a workbench or surface plate are not included.  
The max. acceptable length of the bolt is 50mm for TMU50.

**Caution:** Use after securely bolting to a workbench or surface plate.

**±90° tilt** Solidly fixable at every 45°

The holder can be securely fixed at inclinations of every 45°. Work high in loads such as tightening pullstud bolts can be securely performed.

0°

±45°

±90°



**360° rotation** Ideal for replacing inserts

Mounting is easy and fast, as inserts can be replaced while rotating the holder 360°. (indexable at every 45°)

