

TOOLING MATE

For mounting and removal of pullstud bolts and tools.

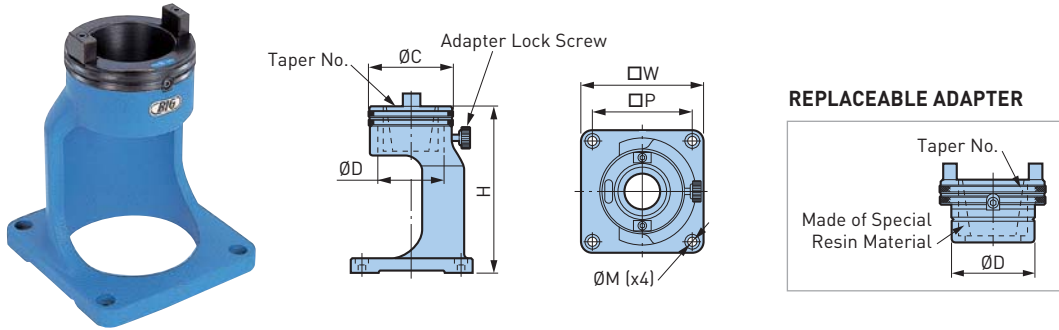

Catalog Number	CV/BT	ØC	ØD	H	□W	□P	ØM	Adapter Model
TMS40-30	30	2.992	2.362	5.906	4.331	3.543	.276 (for M6)	TMA40-30
TMS40-40	40							TMA40-40
TMS50-40	40	4.134	3.465	7.48	6.299	5.118	.354 (for M8)	TMA50-40
TMS50-50	50							TMA50-50

- 1 adapter is included
- Adapters can be ordered individually
- Adapter lock screw is available as a spare part (Model: RTM0615)
- Mounting bolts (4 pcs.) must be ordered separately

CAUTION

TOOLING MATE must be securely fixed to a bench with 4 mounting bolts.

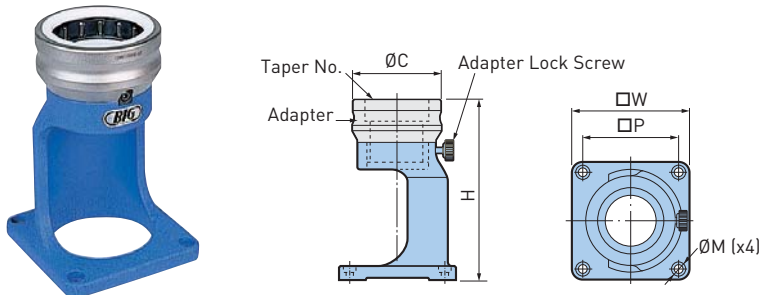

Catalog Number	HSK	BIG CAPTO	ØC	H	□W	□P	ØM	Adapter Model
TMS40-32R	32	—	2.992	6.496	4.331	3.543	.276 (for M6) or UNC 1/4	TMA40-32R
TMS40-40R	40	C4						TMA40-40R
TMS40-50R	50	C5						TMA40-50R
TMS40-63R	63	C6	3.425	6.772	6.299	5.118	.354 (for M8) or UNC 5/16	TMA40-63R
TMS50-80R	80	C8	4.488	8.465				TMA50-80R
TMS50-100R	100	—	4.882	8.622				TMA50-100R

- 1 adapter is included
- Adapters can be ordered individually
- Adapter lock screw is available as a spare part (Model: RTM0615)
- Mounting bolts (4 pcs.) must be ordered separately
- Tooling Mate can be used with BIG CAPTO; polygon taper made by other manufacturers cannot be used

CAUTION

TOOLING MATE must be securely fixed to a bench with 4 mounting bolts.