

CTX beta 800 TC
CTX beta 1250 TC
CTX beta 1250 TC 4A
CTX beta 2000 TC
CTX gamma 1250 TC
CTX gamma 2000 TC
CTX gamma 3000 TC

6-SIDED TURN & MILL COMPLETE MACHINING

CTX TC

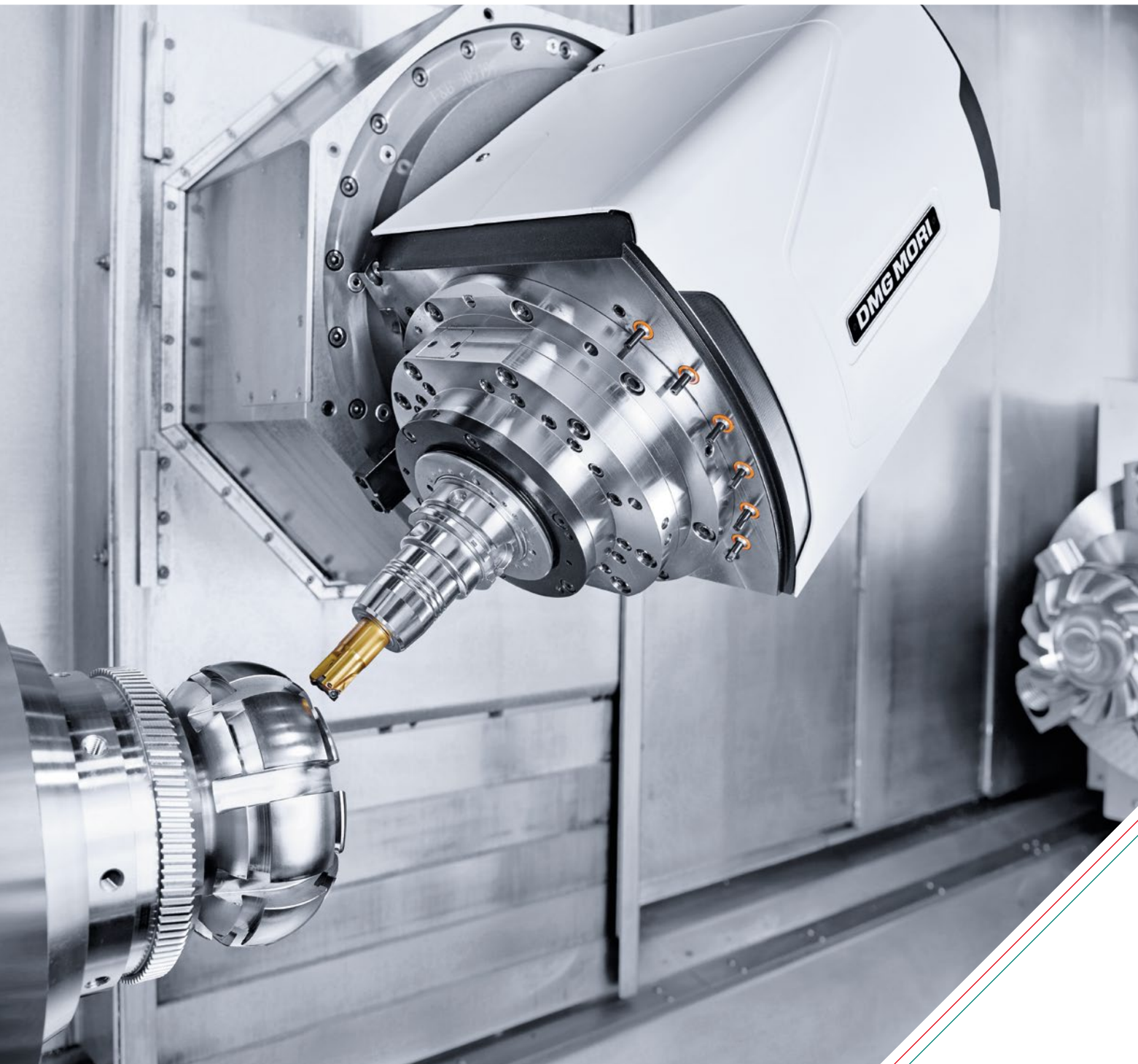

Highlights

Machine and technology

Automation

Applications

Control and technology cycles

Technical data

CTX TC

Six sides. One solution. CTX TC – Turn & Mill machines



DMG MORI

02

CTX TC

Turn & Mill complete machining

- + **Highest precision and lower processing costs** with complete machining in a single setup
- + One **tool carrier as NC-controlled B-axis**
- + Machining of complex workpieces up to **5-axis simultaneous machining**
- + **ShopTurn 3G** for workshop-oriented programming directly on the machine



Mechanical engineering

Sprocket machined
on a CTX beta 800 TC
CK45/11.5 min.



Mechanical engineering

Turret disk machined
on a CTX beta 1250 TC
CK45/180 min.

Flexibility – the added value compared to any universal turning machine



100 % TURNING

- + Up to 700 mm maximum turning diameter due to large axis strokes of the travelling column
- + Up to 4,000 Nm maximum torque on the main spindle
- + 6-sided complete machining with optional counter spindle

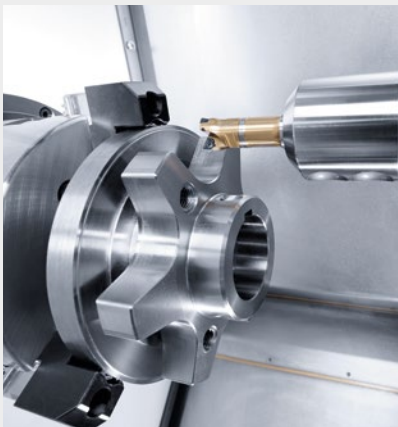

100 % MILLING

- + Up to 420 mm Y-stroke for the excentric machining based on travelling column concept with maximum stability
- + Highest milling performance with the compactMASTER with 120 Nm (CTX beta TC)/220 Nm (CTX gamma TC) and up to 20,000 rpm (12,000 rpm as standard)
- + 5-axis simultaneous machining for the machining of free-form surfaces (with optional DMG MORI technology cycle)



100 % TOOLS

- + Up to 180 tools for highest flexibility during machining and shortest tooling times
- + Disk magazine with 24 (CTX beta TC)/36 stations (CTX gamma TC) as standard
- + Economical standard tools due to freely indexable B-axis with up to $\pm 120^\circ$ swivel range and highest precision (minimal position deviation $< 1 \mu\text{m}$)

Highlights

Machine and technology

Automation

Applications

Control and technology cycles

Technical data

CTX TC

Parallel machining due to second tool carrier



5-axis production turning
CTX beta 1250 TC 4A
CTX gamma TC (with optional turret)

- + **Highly productive machines** for the production of medium to large batch sizes
- + **Highest productivity** through the parallel use of two tool carriers
- + **Turret with highest long-term accuracy** due to TRIFIX® precision interface for <30sec. tool setup time
- + **Ideally suited to series production** due to optional automation solutions like for example integrated handling system or gantry loading



Aerospace

Diffuser produced
on a CTX gamma 1250 TC
Titanium / 6 hours

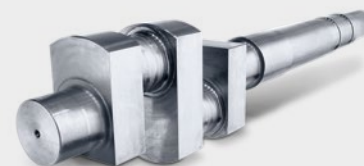

Mechanical engineering

Marine crankshaft produced
on a CTX gamma 3000 TC
42CrMo4 / 280 min.

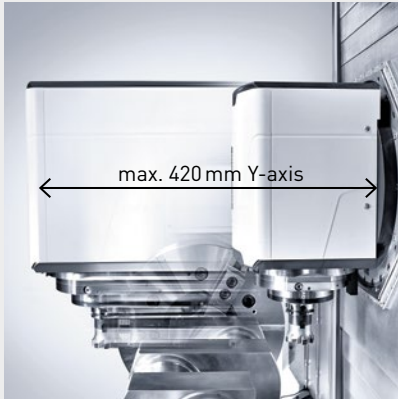

MAXIMUM STABILITY AND CUTTING PERFORMANCE DUE TO HIGHLY STABLE TRAVELLING COLUMN CONCEPT

- + **Up to 750 mm wide distance between the linear guides** of the travelling column
- + **Highest stability and optimum force transmission** into the machine bed by means of five positioning shoes* for heavy-duty machining
- + **Turning-milling spindle** HSK-A63 and 220 Nm torque**
Unrestricted use of HSK-T tools

*6 positioning shoes in the CTX beta 1250 TC/TC 4A
** CTX beta TC: Max. 120 Nm

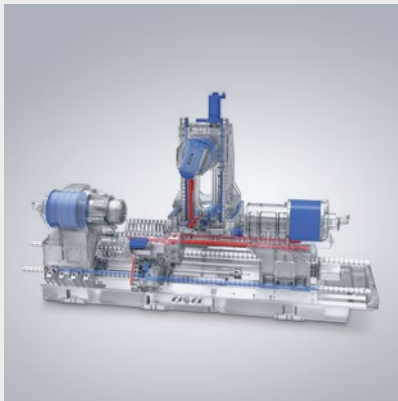

HIGHEST PRECISION AND LONG-TERM ACCURACY

- + **Highest precision due to direct measuring systems in all axes**
- + **Maximum thermal stability** due to dynamic spindle length compensation as well as liquid-cooled integrated spindle motors and headstocks
- + **Maintenance-free linear drive in the Z-axis*** with 5 years warranty and 70 m/min rapid traverse for highest dynamics and long-term accuracy

*Optional for CTX beta 1250 TC/CTX gamma 1250/2000 TC



OPTIMUM ACCESSIBILITY AND ERGONOMICS

- + **Low depth of engagement** up to the main spindle for the ergonomic loading and unloading (e.g. CTX beta 800 TC: 400 mm)
- + **Maximum visibility** of the machining compartment for best control
- + **Continuously variable adjustability** of screen and keyboard
- + **Shorter service times** due to optimum accessibility of the travelling column and further components



3D CONTROL TECHNOLOGY AND EXCLUSIVE TECHNOLOGY CYCLES FROM DMG MORI

- + **CELOS from DMG MORI** with 21.5" ERGOline and SIEMENS –
Up to 30% faster setup due to the complete integration of the machine into the company organisation
- + **Exclusive DMG MORI technology cycles** – 60% shorter programming time due to parameterised context menus and simple entry of the parameters into the dialog; no complicated DIN programming

Highlights

Machine and technology

Automation

Applications

Control and technology cycles

Technical data

CTX beta TC

Universal Turn & Mill complete machining for workpieces up to \varnothing 700 mm



HIGHLIGHTS

- + **Highest milling performance with the compactMASTER** with 120 Nm and up to 20,000 rpm (12,000 rpm as standard)
- + **Up to 300 mm Y-stroke** for the excentric machining based on travelling column concept with maximum stability
- + **6-sided complete machining** with main spindle and optional counter spindle up to 700 Nm
- + **Bar machining up to $\varnothing 104$ mm,** chuck up to $\varnothing 400$ mm



		CTX beta 800 TC	CTX beta 1250 TC (<i>linear</i>)	CTX beta 1250 TC 4A	CTX beta 2000 TC
Max. Turning length	mm	750	1,200	1,185	2,000
Max. Turning diameter (Disk/Chain magazine)	mm	$\varnothing 450/500$	$\varnothing 470/500$	$\varnothing 500$	$\varnothing 630/700$
Turning-milling spindle/speed	rpm	12,000	12,000	12,000	12,000
Torque/power (40% DC)	Nm/kW	120/22.5	120/22.5	120/22.5	120/22.5
Tool magazine	Stations	24 (max. 80)	24 (max. 80)	24 (max. 120)	24 (max. 100)
X/Y/Z Stroke travelling column slide	mm	480/ ± 100 /845	490/ ± 125 /1,300	490/ ± 100 /1,200	650/ ± 150 /2,050
Main spindle/speed	rpm	ISM 76/5,000	ISM 76/5,000	ISM 76/5,000	ISM 76/5,000
Torque/power (40% DC)	Nm/kW	360/32	360/32	360/32	360/32
Counter spindle (optional)/speed	rpm	ISM 52/6,000	ISM 76/5,000	ISM 76/5,000	ISM 76/5,000
Torque/power (40% DC)	Nm/kW	200/14.5	360/32	360/32	360/32
Footprint incl. chip conveyor	m ²	10.2	12.1	17.1	18.6

Highlights

Machine and technology

Automation

Applications

Control and technology cycles

Technical data

CTX gamma TC

6-sided complete machining of workpieces up to 3 m length



08

		CTX gamma 1250 TC <i>(linear)</i>	CTX gamma 2000 TC <i>(linear)</i>	CTX gamma 3000 TC
Max. Turning length	mm	1,250	2,000	3,000
Max. Turning diameter (Disk/Chain magazine)	mm	ø 630/700	ø 630/700	ø 630/700
Turning-milling spindle/speed	rpm	12,000	12,000	12,000
Torque/power (40% DC)	Nm/kW	220/36	220/36	220/36
Tool magazine	Stations	36 (max. 180)	36 (max. 180)	36 (max. 180)
X/Y/Z Stroke travelling column slide	mm	800/±210/1,300	800/±210/2,050	800/±210/3,050
Main spindle/speed	rpm	ISM 102/4,000	ISM 102/4,000	ISM 127/2,500
Torque/power (40% DC)	Nm/kW	700/40	700/40	2,200/52
Counter spindle (optional)/speed	rpm	ISM 76/5,000	ISM 76/5,000	ISM 102/4,000
Torque/power (40% DC)	Nm/kW	360/32	360/32	700/40
Footprint incl. chip conveyor	m ²	18.4	20.4	23.0

HIGHLIGHTS

- + **compactMASTER II** – 220 Nm at just 450 mm length
- + 800 mm X-stroke and 420 mm Y-stroke for **maximum flexibility** during radial machining
- + 550 mm long tools, **horizontally drill through or unscrew workpieces with 550 mm length** (CTX gamma 1250 TC up to 340 mm)
- + **6-sided complete machining** with main spindle up to 4,000 Nm and counter spindle* up to 2,200 Nm, chuck* up to $\varnothing 630$ mm
- + **Production turning with B-axis** and lower turret* with up to 16 driven tools

* Option



CTX TC

Highest stability and long-term accuracy

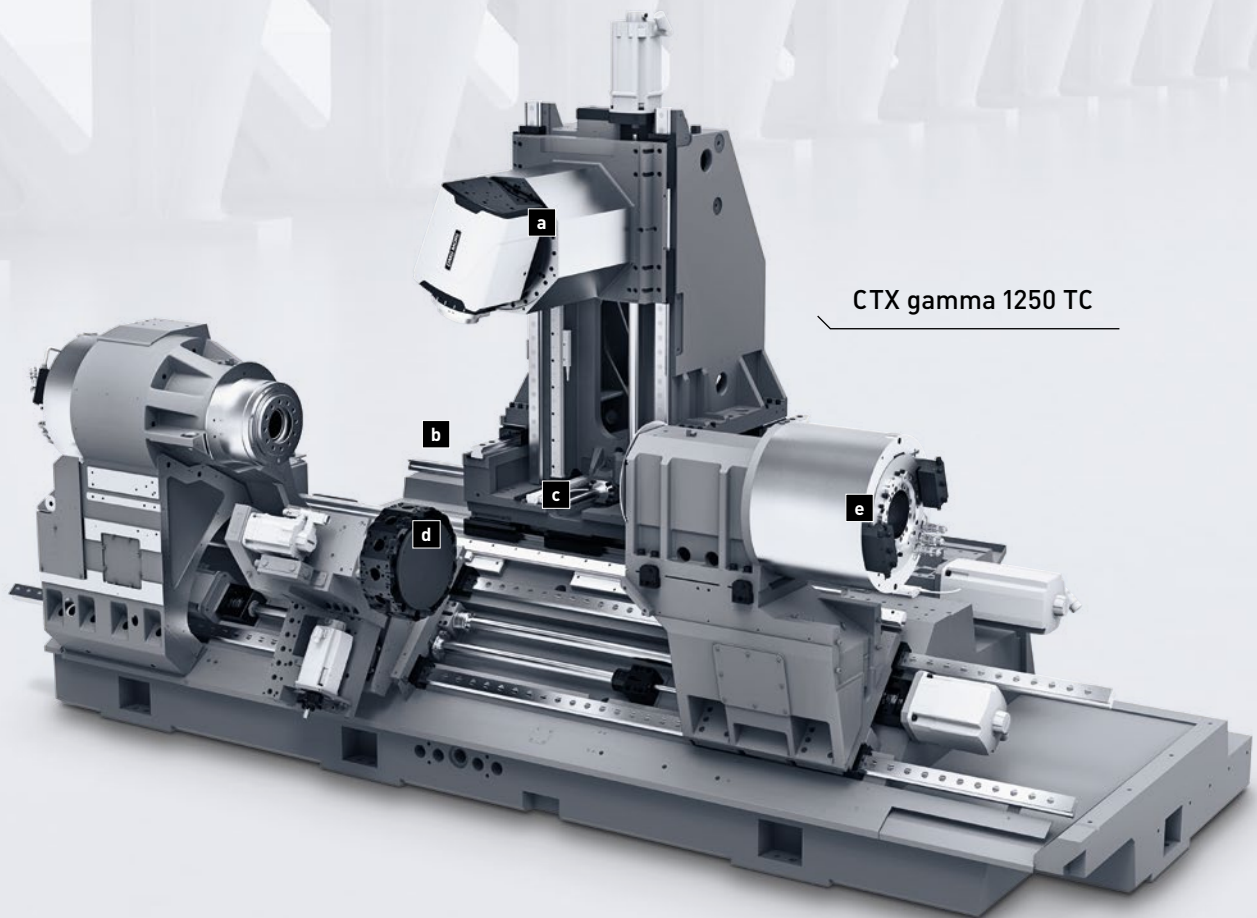

CTX gamma 1250 TC

- a B-axis with DirectDrive**
for top precision and dynamics up to 100 rpm
- b Constant rigidity**
Thanks to robust guides up to size 55 and up to $\varnothing 50$ mm ball screw drives
- c Wide distance between the guideways of the travelling column**
CTX beta TC: 400/630/425 mm (X/Y/Z)
CTX beta 1250 TC: 400/645/475 mm (X/Y/Z)
CTX gamma TC: 545/740/752 mm (X/Y/Z)

- d Turret**
VDI interface, play-free and spring-loaded double centring and increased rigidity thanks to large interface with bolt-hole pattern
- e Thermal stability**
Liquid cooling of all relevant components: Machine bed, spindle motors, feed motors, linear guides and ball screw spindles

High-quality components – designed for any application

CTX beta 800 TC	CTX beta 1250 TC	CTX beta 1250 TC 4A	CTX beta 2000 TC	CTX gamma 1250/2000/3000 TC
45 mm roller guides	45 mm roller guides	45 mm roller guides	55 mm roller guides	55 mm roller guides
40 mm ball screw	40 mm ball screw	40 mm ball screw	55 mm ball screw	50 mm ball screw
Linear measuring systems in the linear axes of the travelling column (X1/Y1/Z1)				
-	-	Linear measuring systems in Z3 optional (counter spindle)	Linear measuring systems in Z3 optional (counter spindle/tailstock)	Linear measuring systems in Z3 optional (counter spindle/tailstock)
-	-	Linear measuring systems in X2, in Y2/Z2 optional (turret)	-	TC 4A: Linear measuring systems in X2/Z2 (turret)
		Cooling of turret drives		Cooling of turret drives



ACCURACY AND THERMAL STABILITY

Highest precision and thermal stability

Dynamic spindle length compensation

1. Temperature sensor 

2. Compensation model

- + Conventional : $\Delta X = \alpha \times \Delta T$
- + DMG MORI: Non-linear dynamic model

3. Adjustment of the axis nominal values

- + Conventional: Linear compensation
- + DMG MORI: 5-axis geometrical compensation

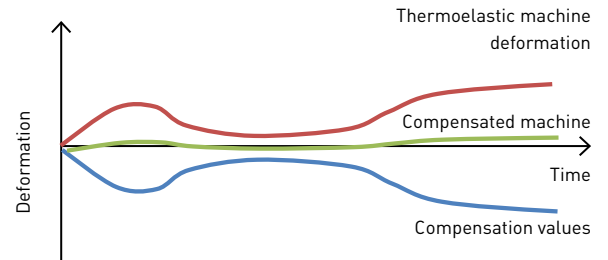

- + The compensation values offset the thermal deformation
- + A thermally stable machine is achieved

compactMASTER

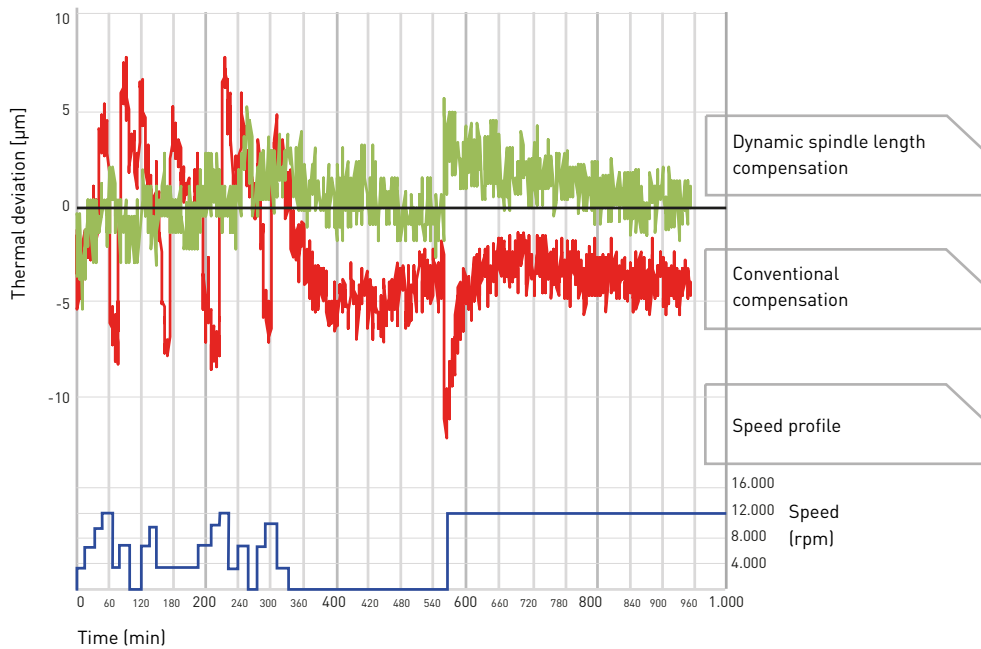

Concentricity on the workpiece (scale 0.5 μm/div.)

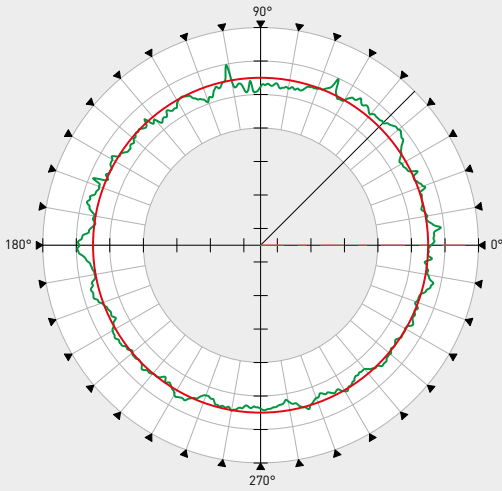

< 0.6 μm roundness on the workpiece during turning

Workpiece	ø 42 mm cut-off, aluminium 80 mm projecting length, directly clamped in the spindle
Clamping	
Cutting speed	Vc = 280 m/min
Depth of cut	ap = 0.2 mm
Feed rate	f = 0.1 mm/rpm
Tool	Diamond tool

Precision in the μ-range

	Positioning accuracy (P _{max})	Repeat accuracy (Ps _{max})
X-axis	< 0.006 mm	< 0.002 mm
Y-axis	< 0.006 mm	< 0.002 mm
Z-axis	< 0.01 mm	< 0.003 mm
C-axis	< 0.0042 °	< 0.0014 °

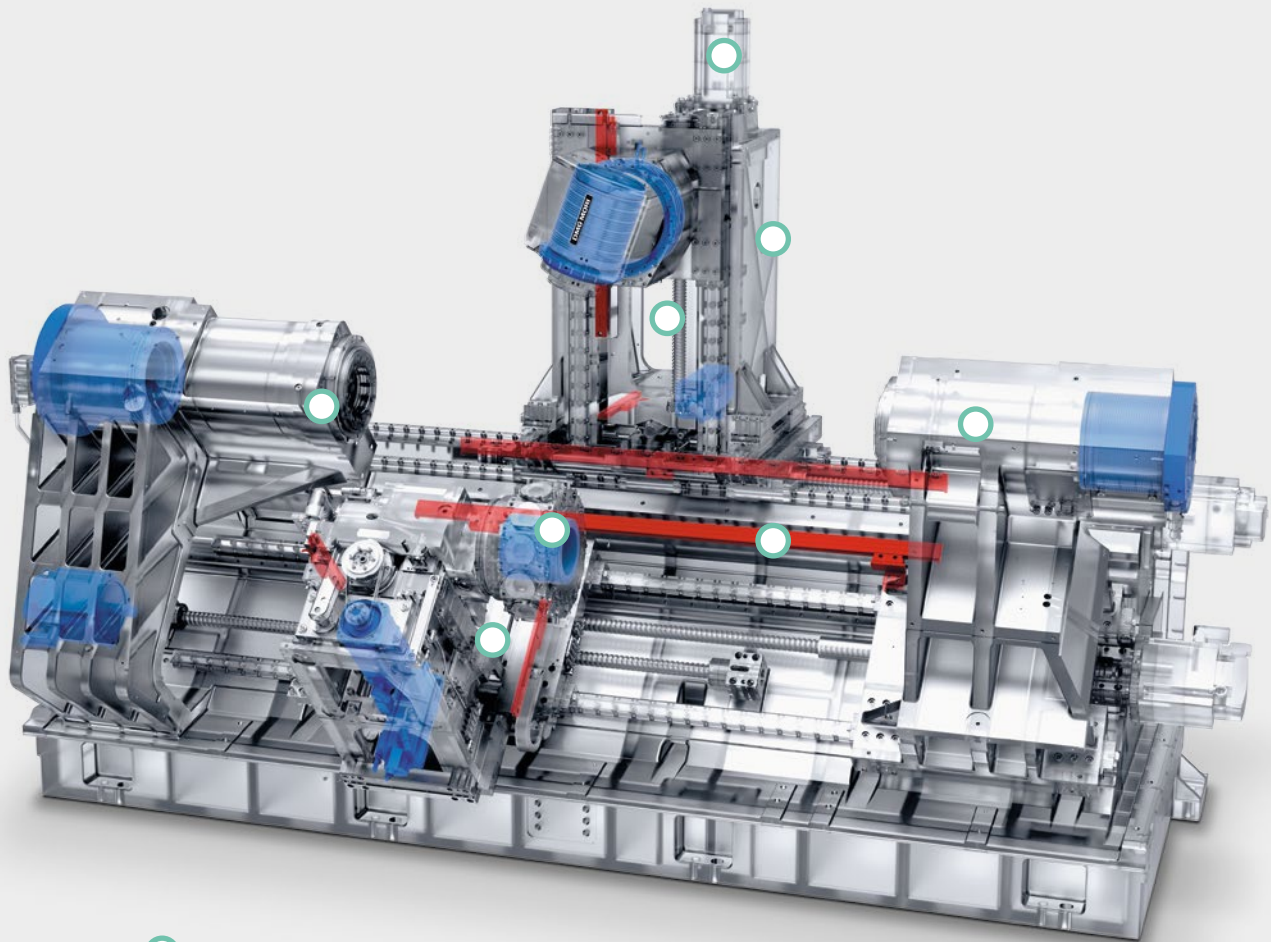

- Temperature sensor
- Blue: cooled elements
- Red: Linear measuring systems

TURN & MILL

Demand-based expansion stages for maximum productivity

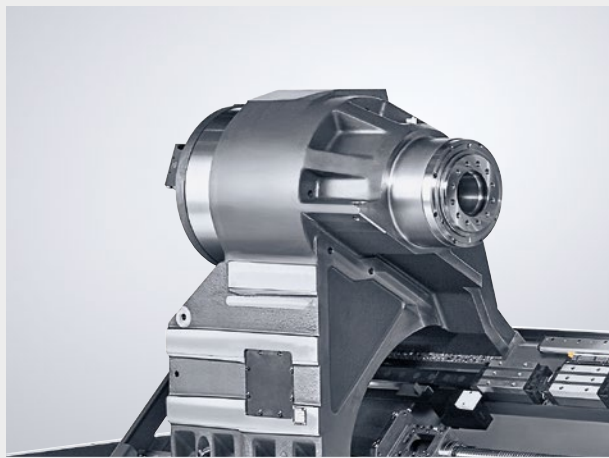

MAIN AND COUNTER SPINDLE AS INTEGRATED SPINDLE MOTOR

- + Main spindle up to 5,000 rpm or 59 kW and 4,000 Nm
- + Counter spindle up to 6,000 rpm or 52 kW and 2,200 Nm
- + Hydraulic partial hollow clamping device, optional with hollow clamping device for bar machining up to $\varnothing 127$ mm

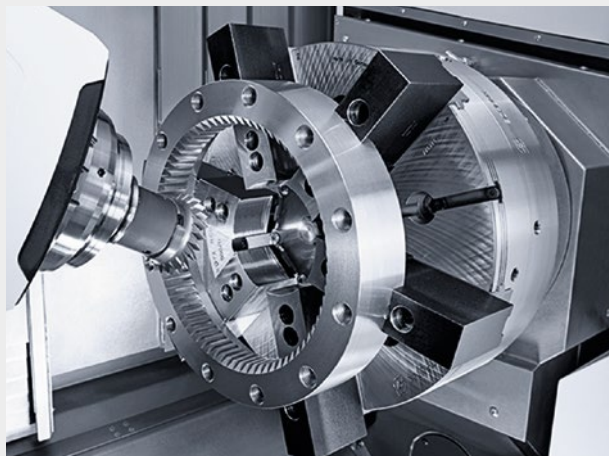

USAGE OF CHUCK UP TO $\varnothing 630$ mm DUE TO HIGHLY STABLE MACHINE CONCEPT AND HIGH-TORQUE SPINDLES

- + CTX beta TC: Up to $\varnothing 400$ mm clamping diameter
- + CTX gamma TC: Up to $\varnothing 630$ mm clamping diameter
- + Special solutions like magnetic chucks on request

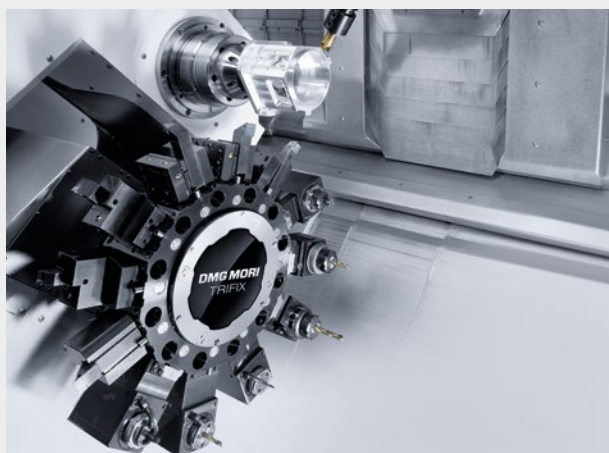

SHORTER JOB TIMES THANKS TO PARALLEL MACHINING WITH LOWER TURRET*

- + 12 driven tools VDI 40 or 16 driven tools VDI 30
- + Optional as DirectDrive with 10,000 rpm
- + Compound slide with absolute, direct travel measuring systems for more accurate startup**

* Standard for CTX beta 1250 TC 4A, optional for all CTX gamma TC **Option



AUTOMATICALLY MOVABLE STEADY RESTS FOR THE VIBRATION-FREE MACHINING OF LONG COMPONENTS LIKE SHAFTS

- + Up to $\varnothing 460$ mm workpiece diameter (procedure via own NC-axis)
- + 50% shorter setup time due to optional quick-change system with double cone clamping and $3\ \mu\text{m}$ repeat accuracy
- + Self-centring, hydraulic steady rest head

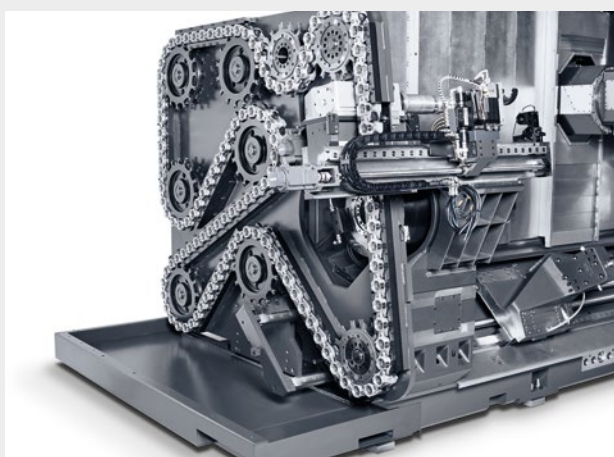

SHORTER TOOLING TIMES THANKS TO TOOL MAGAZINES UP TO 180 STATIONS

- + Disk magazine with 24/36 stations as standard (CTX beta TC/CTX gamma TC)
- + Up to 180 tools with optional chain magazine
- + Tool holder HSK-A 63 as standard. HSK-A100/Capto C6/Capto C8 optional
- + Tools up to 500 mm (disk magazine)/ 550 mm (chain magazine)
- + Tool weight up to 25 kg, 750 kg total load



ADDITIONAL MAGAZINE FOR UP TO 6 OVERSIZED TOOLS VIA TAILSTOCK/COUNTER SPINDLE*

- + Tools up to 700 mm and 15 kg for deep holes
- + Automatically replaceable tools with the turning/milling spindle
- + Tool holder HSK-A63/HSK-A100/Capto C6/Capto C8
- + Total load of 120 kg

* Available for CTX beta 2000 TC, CTX gamma TC

TURN & MILL

High-performance turning up to 59 kW and 4,000 Nm torque

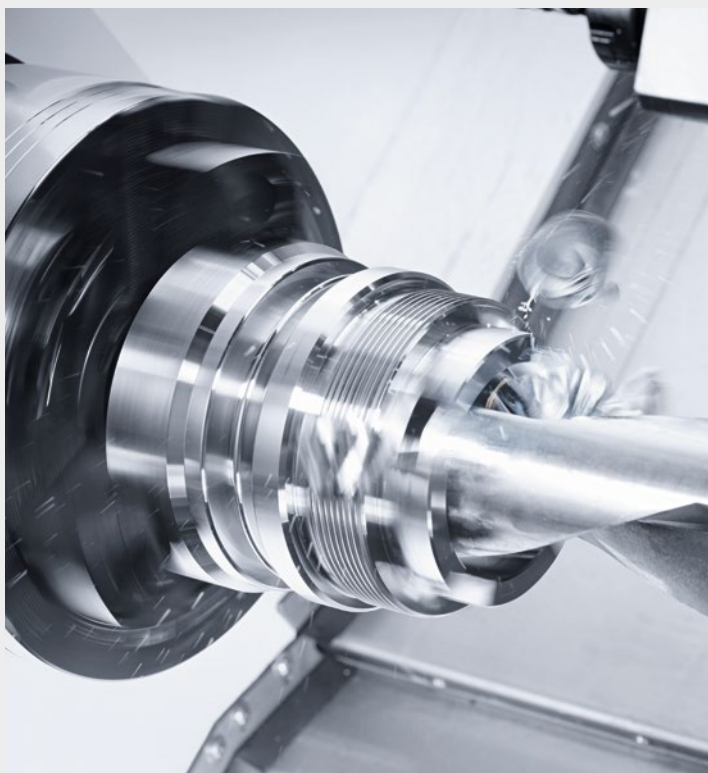

HIGHLIGHTS

- + **Top dynamics** due to integrated spindle drives up to 6,000 rpm or 4,000 Nm and integrated C-axis (0.001°)
- + **Maximum precision and thermal stability** due to liquid-cooled drives of the main and counter spindle
- + **6-sided complete machining** due to main and counter spindle
- + **Easy to service spindle construction** due to cartridge principle

		ISM 52 6,000 rpm 14.5/12.5 kW 200/170 Nm	ISM 76 5,000 rpm 32/25 kW 360/280 Nm	ISM 102 4,000 rpm 40/33 kW 700/580 Nm	ISM 102 Plus 2,500 rpm 52/40 kW 2,200/1,700 Nm	ISM 127 2,500 rpm 52/40 kW 2,200/1,700 Nm	ISM 127 Plus 2,000 rpm 59/50 kW 4,000/3,400 Nm
High-performance roughing (Ck45)							
Workpiece diameter	mm	75	150	200	400	400	500
Material removal rate	cm ³ /min	540	540	864	1,080	1,080	1,584
Depth of cut	mm	5	5	8	10	10	12
Cutting speed	m/min	240	240	240	240	240	240
Feed	mm/rpm	0.45	0.45	0.45	0.45	0.45	0.55
High-performance drilling (Ck45)							
Tool diameter	mm	55	55	70	105	105	105
Spindle speed	rpm	750	750	609	242	242	242
Cutting speed	m/min	130	130	134	80	80	80
Feed	mm/rpm	0.18	0.2	0.2	0.2	0.2	0.2

TOP DYNAMICS DUE TO INTEGRATED SPINDLE DRIVES



	CTX beta 800 TC		CTX beta 1250 TC		CTX beta 1250 TC 4A		CTX beta 2000 TC		CTX gamma 1250 TC		CTX gamma 2000 TC		CTX gamma 3000 TC	
	HS	GS	HS	GS	HS	GS	HS	GS	HS	GS	HS	GS	HS	GS
ISM 52 6,000 rpm 14.5/12.5 kW 200/170 Nm 51 (65) mm 140h5		◦		◦										
ISM 76 5,000 rpm 32/25 kW 360/280 Nm 67 (77) mm 170h5	•		•	◦	•	•	•	◦		◦		◦		
ISM 102 4,000 rpm 40/33 kW 700/580 Nm 95 (104) mm 220h5	◦		◦		◦*	◦*	◦	◦	•	◦	•	◦		◦
ISM 102 Plus 2,500 rpm 52/40 kW 2,200/1,700 Nm 95 (104) mm 220h5									◦	◦	◦	◦		◦
ISM 127 2,500 rpm 52/40 kW 2,200/1,700 Nm 125 (127) A15									◦	◦	◦	◦	•	◦
ISM 127 Plus 2,000 rpm 59/50 kW 4,000/3,400 Nm 125 (127) A15									◦	◦	◦	◦		◦

• Standard • Option * other performance data (see page 40)

Highlights

Machine and technology

Automation

Applications

Control and technology cycles

Technical data

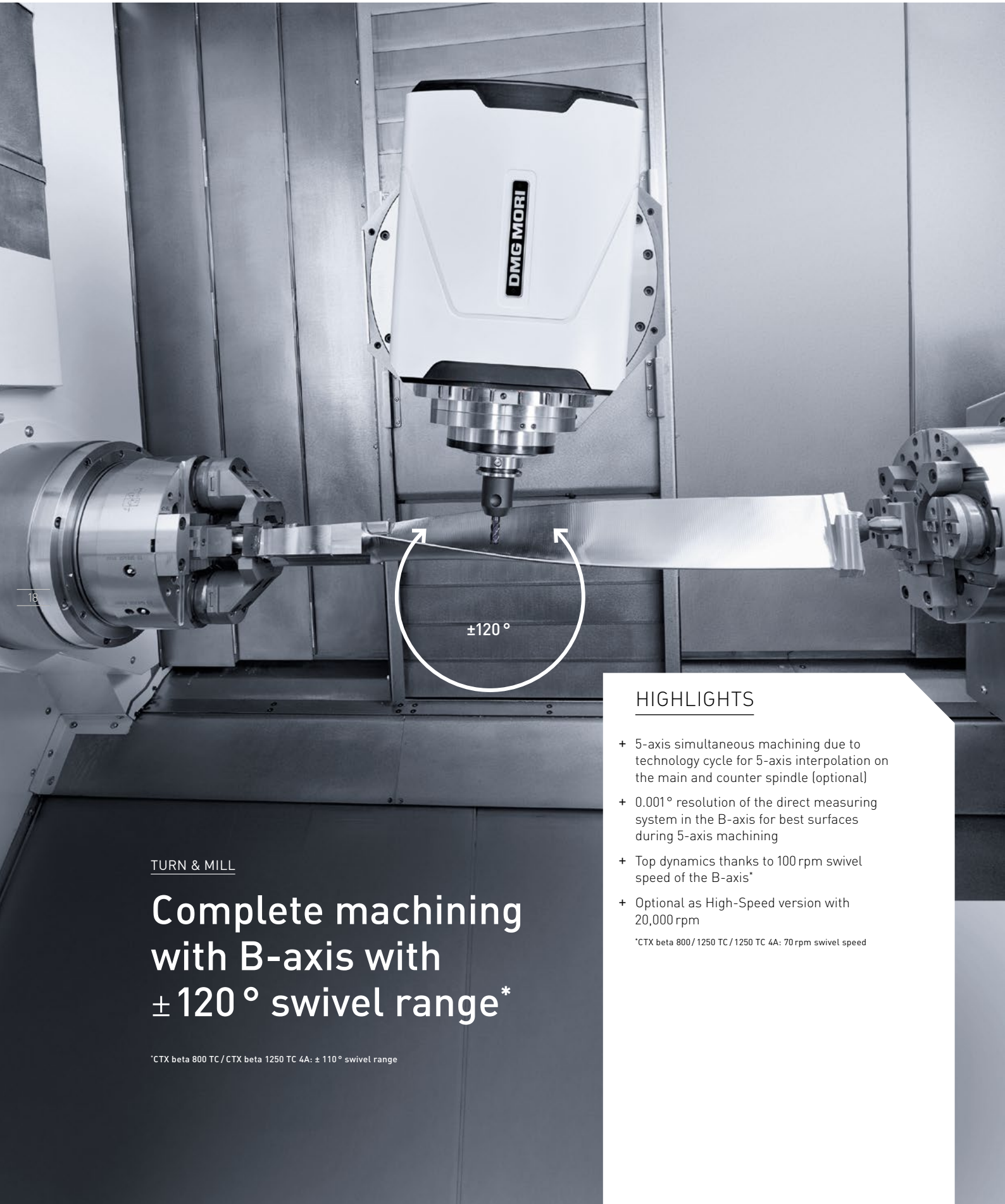

TURN & MILL

Complete machining with B-axis with $\pm 120^\circ$ swivel range*

*CTX beta 800 TC / CTX beta 1250 TC 4A: $\pm 110^\circ$ swivel range

HIGHLIGHTS

- + 5-axis simultaneous machining due to technology cycle for 5-axis interpolation on the main and counter spindle (optional)
- + 0.001° resolution of the direct measuring system in the B-axis for best surfaces during 5-axis machining
- + Top dynamics thanks to 100 rpm swivel speed of the B-axis*
- + Optional as High-Speed version with 20,000 rpm

*CTX beta 800/1250 TC / 1250 TC 4A: 70 rpm swivel speed

		CTX beta TC Standard spindle	CTX gamma TC Standard spindle	CTX beta / gamma TC High-speed spindle
High-performance milling (Ck45)		12,000 rpm 22.5/19 kW 120/85 Nm	12,000 rpm 36/27 kW 220/160 Nm	20,000 rpm 22.5/19 kW 120/85 Nm
Material removal rate	cm ³ /min	530	592	530
Spindle speed	rpm	1,768	1,300	1,768
Power	kW	18.8	25	18.8
Torque	Nm	101	186	101
Feed	mm/tooth	0.2	0.2	0.2
Depth / width of cut	mm	10/30	13/35	10/30
Cutting speed	m/min	350	255	350
Number of teeth		5	5	5
Milling diameter	mm	63	63	63
Spec. cutting force	N/mm ²	1,910	1,920	1,910
High-performance drilling (Ck45)				
Material removal rate	cm ³ /min	92	295	16
Spindle speed	rpm	4,570	2,030	16,970
Feed	m/min	450	360	2,037
Tapping (Ck45)				
Thread size	mm	M20 × 2.5	M27 × 2	M20 × 2.5
Spindle speed	rpm	606	295	606

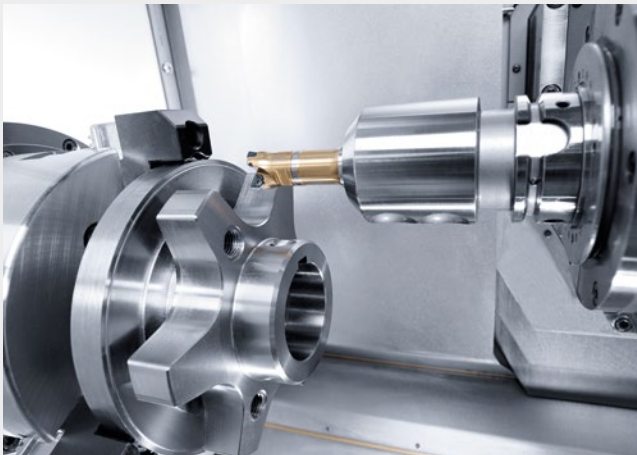

LOWEST TOOL COSTS

- + Usage of standard tools
- + Tools usable for machining on main and counter spindle
- + Usage of less expensive milling tools thanks to DirectDrive B-axis



DirectDrive FOR UP TO 100rpm RAPID TRAVERSE

- + B-axis with DirectDrive for top dynamics and 50m/min rapid traverse speed
- + ±120° swivel range of the B-axis*
- + 6,000Nm holding torque

*CTX beta 800 TC / 1250 TC 4A: 110° swivel range

TURN & MILL

Optimum usage of the machining compartment – thanks to ultra-compact compactMASTER

- + Space gain of 170 mm with the CTX beta TC and 70 mm with the CTX gamma TC (compared to 1st generation)
- + Highest milling performance thanks to 120 Nm/220 Nm torque (CTX beta/gamma TC)
- + Up to 20,000 rpm with optional high-speed spindle

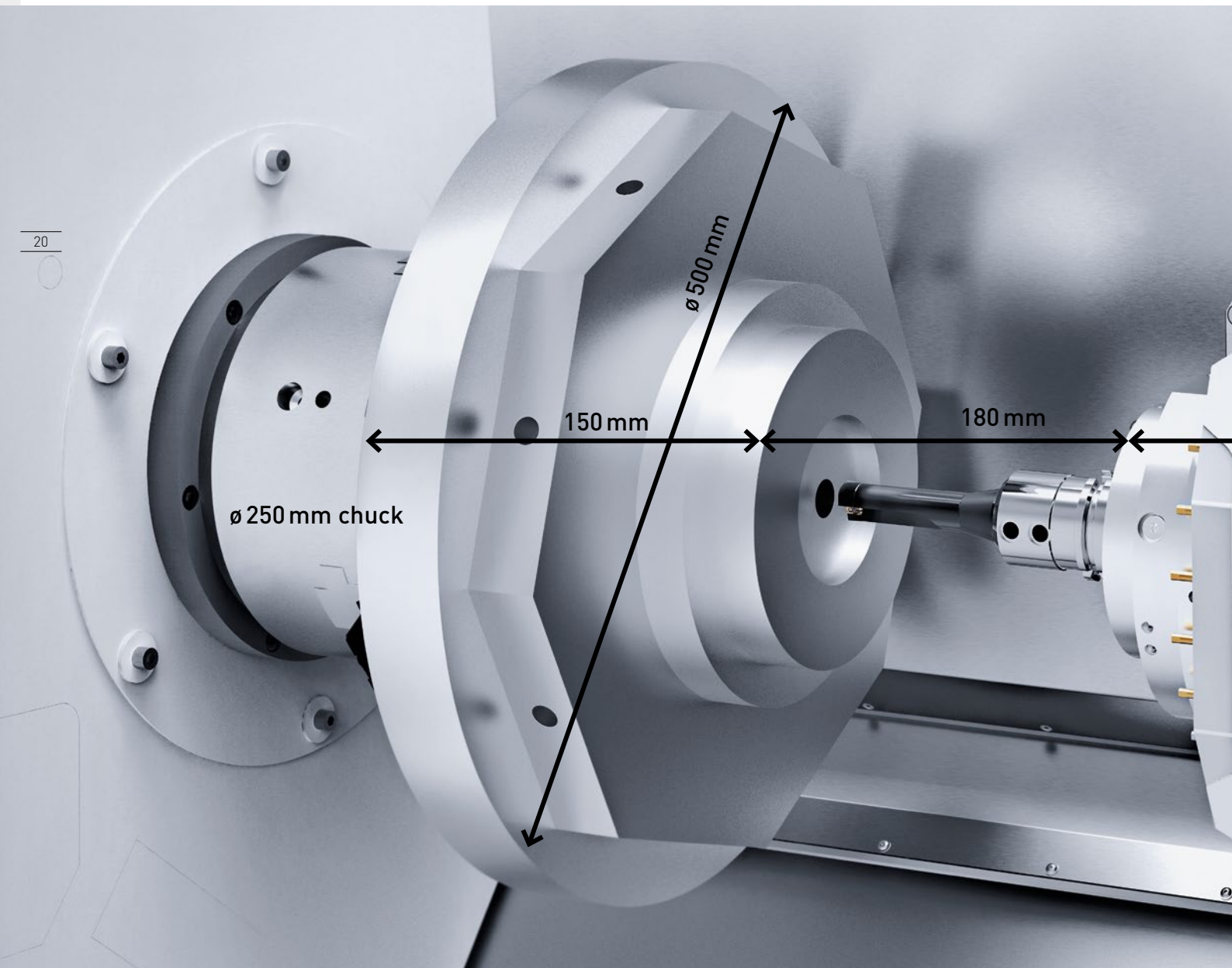

CTX beta TC: compactMASTER size 1

- + As standard for all CTX beta TC machines
- + Drill workpieces up to $\varnothing 220/230/300$ mm up to rotation centre (CTX beta 800/1250/2000 TC)
- + Drill workpieces up to $\varnothing 150/150/200$ mm vertically (CTX beta 800/1250/2000 TC)

CTX gamma TC: compactMASTER size 2

- + As standard for all CTX gamma TC machines
- + Drill workpieces up to $\varnothing 450$ to the center line
- + Completely drill workpieces up to $\varnothing 300$ mm vertically

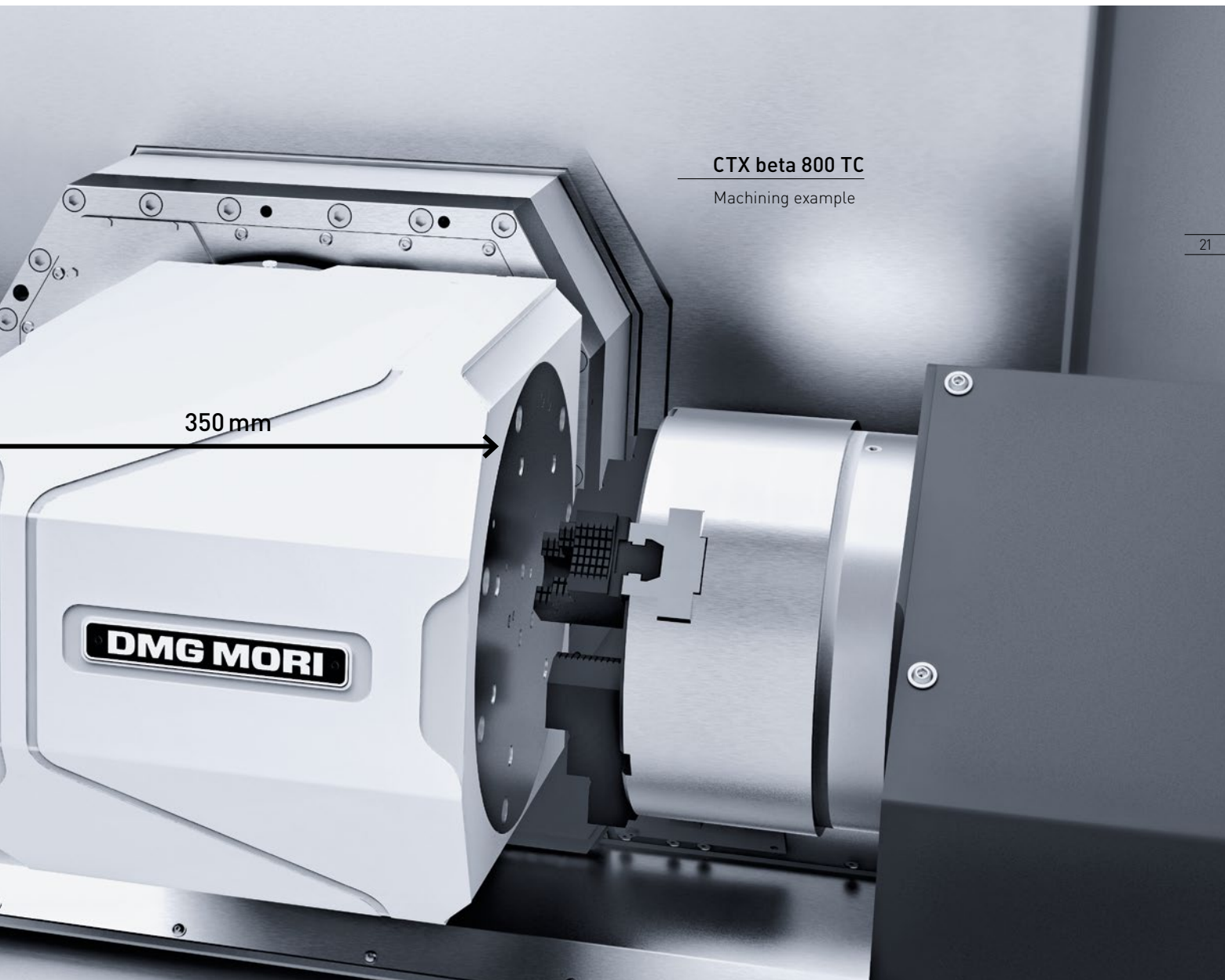

CTX beta 800 TC

Machining example

Minimum setup time thanks to large tool magazines with up to 180 stations



1

FLEXIBLE TOOL HANDLING FOR COMPLEX MACHINING

- + As standard with 24- /36-station disk magazine (CTX beta/gamma TC)
- + Chain magazines with up to 180 tool stations
- + Tools up to $\varnothing 140$ mm and 550 mm length for deep hole drilling
- + Setup of tools through the magazine door simultaneously to the machining process possible
- + Can be flexibly used for HSK-A63/HSK-T63/Capto C6 or HSK-A100/HSK-T100/Capto C8 holders*
- + Low downtimes by using sister tools
- + Shortest tool change times from 1.2 sec.
- + Shorter idle times thanks to automatic sorting of the tools in the magazine, with the optional tool sorting cycle

*HSK-A100 and Capto C8 available for CTX gamma TC-series

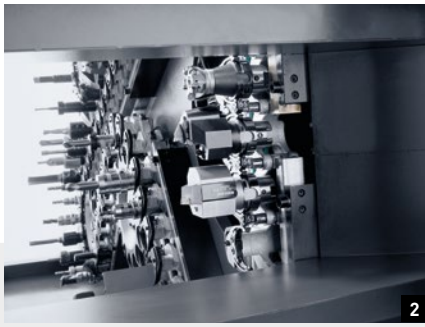

1: Tool chain magazine for up to 180 tools 2: Tool loading station with optimum accessibility from the front 3: Additional magazine for 6 oversized tools up to 700 mm length or ø200 mm (optional for all CTX gamma TC machines) 4: Disk magazine with 36 stations

		CTX beta 800 TC	CTX beta 1250 TC	CTX beta 1250 TC 4A CTX beta 2000 TC	CTX gamma TC	
Disk magazine tool data						
Tool holder		HSK-A63/Capto C6*	HSK-A63/Capto C6*	HSK-A63/Capto C6*	HSK-A63/Capto C6*	
Max. Tool diameter	mm	ø 125	ø 125	ø 125	ø 140	
Max. Tool length	mm	300	300	300	500	
Max. Weight per tool	kg	7	7	7	12	CTX gamma TC
Chain magazine tool data						
Tool holder		HSK-A63/Capto C6*	HSK-A63/Capto C6*	HSK-A63/Capto C6*	HSK-A63/Capto C6*	HSK-A100*/Capto C8*
Max. Tool diameter	mm	ø 120	ø 120	ø 120/140**	ø 140	ø 140
Max. Tool length	mm	300	400	400	550	550
Max. Weight per tool	kg	12	12	12	15	25

* Option ** ø 120 mm: CTX beta 1250 TC 4A / ø 140 mm: CTX beta 2000 TC

CTX gamma 3000 TC

Long boring bar – borings up to 800 mm

Long boring bar (LBB) for central boring with extra long boring bars

- + Boring bars can be used up to 800 mm length or ø123 mm
- + Clamping via bevel clamping system in additional magazine
- + Space for two extra long boring bars
- + Fully automatic tool change in connection with HSK-A100/Capto C8 and ATC boring bar (530 mm / ø123 mm)



CTX beta 1250 TC 4A/CTX gamma TC

Maximum productivity due to parallel machining with two tool carriers

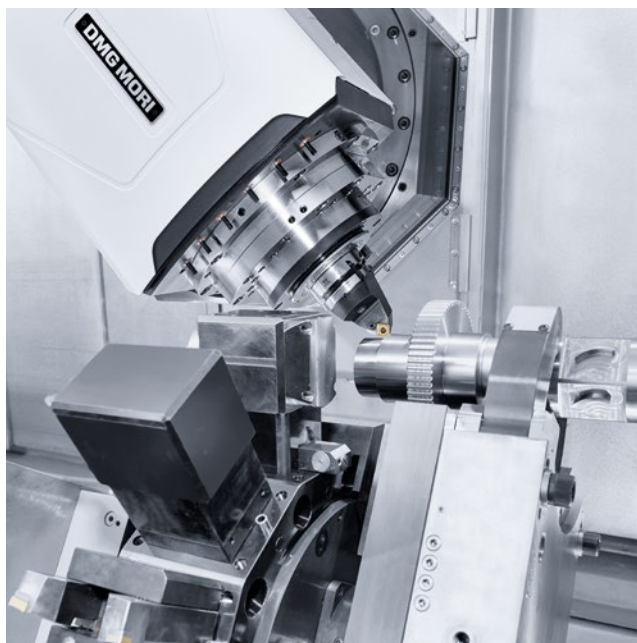

STEADY REST FOR TURRET*

- + Use of a hydraulically operated steady rest for supporting long and slim components
- + Workpieces up to $\varnothing 165$ mm clamping diameter
- + Steady rest for turret possible on all turrets
- + Technology cycle for simple selection of steady rest via dialog programming from the tool store; the cycle enables the startup as well as free travel of the steady rest

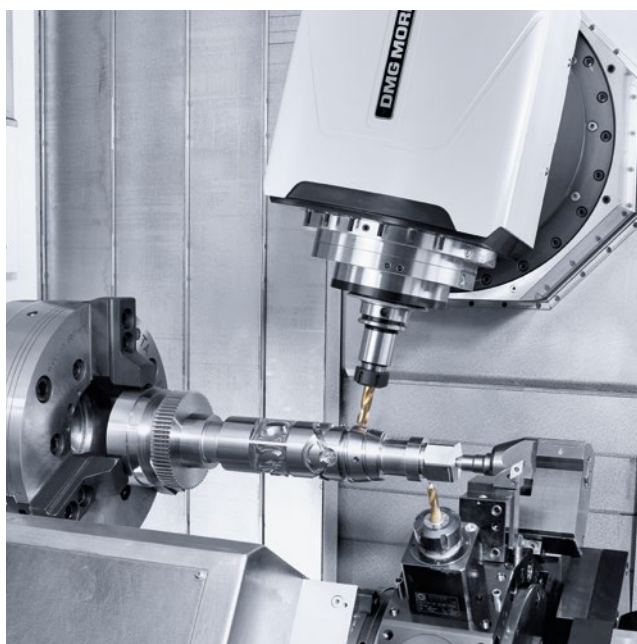

TAILSTOCK FOR TURRET*

- + Usage of a centring pin mounted on the turret
- + Application for fixed or spring-loaded centring pins
- + Technology cycle for simple selection of centring pin from the tool store

*Option



TRIFIX® quick-change system

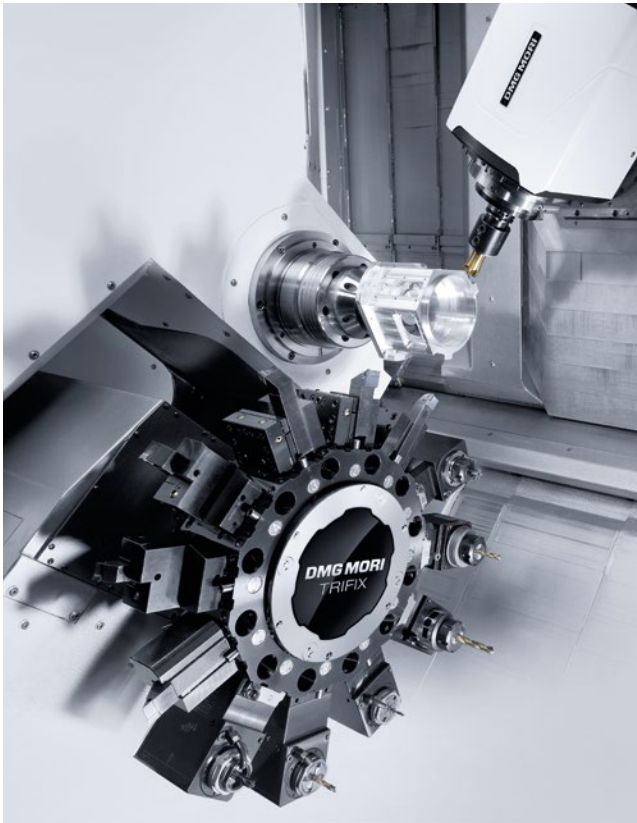

TRIFIX® – FAST AND PRECISE SETTING WITH VDI COMPATIBILITY

- + As standard for all star turrets
- + <30 sec. tool setup time due to VDI with TRIFIX®
- + <6 µm repeatability (same tool, same position)
- + <10 µm positioning accuracy from one station to the next
- + Fully aligned driven tools

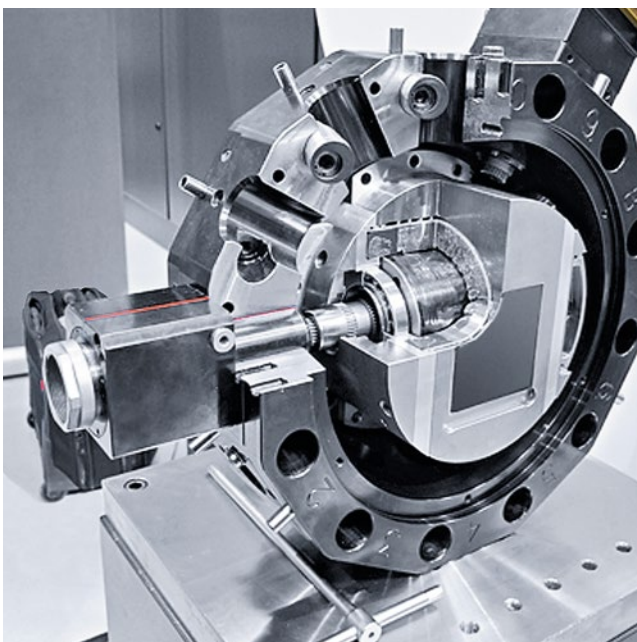

DirectDrive TURRET* WITH 10,000 rpm, FOR OPTIMUM MATERIAL REMOVAL RATE

- + Low-wear DirectDrive with low heat generation thanks to the elimination of the transmission
- + Runs more quietly thanks to the gear-free drive
- + Higher speed, performance and torque compared to conventional drives: 12-station VDI 40 turret with 10,000 rpm, 14.2 kW and 34 Nm
- + Top cutting performance with up to 136 Nm torque due to compact design of the turret and tools with gear reduction ratio up to 4 : 1

* Option

CTX beta 1250 TC 4A/CTX gamma TC

Production turning – turret up to 10,000 rpm or 36 Nm for highest material removal rate

		CTX beta 1250 TC 4A	CTX beta 1250 TC 4A DirectDrive turret	CTX gamma TC
High-performance milling (Ck45)		12×VDI 40 (16×VDI 30) 4,000 rpm 10/8 kW 36/32 Nm	12×VDI 40 10,000 rpm 14.2/10.9 kW 34/26 Nm	12×VDI 40 4,000 rpm 10/8 kW 28/22 Nm
Tool drive		1:1	1:1	1:1
Material removal rate	cm ³ /min	152	267	153
Spindle speed	rpm	2,546	5,570	3,183
Power	kW	7.18	12.57	7.18
Torque	Nm	26.9	21.56	21.56
Feed	mm/tooth	0.15	0.15	0.15
Depth/width of cut	mm	4/25	4/20	4/20
Cutting speed	m/min	200	350	200
Number of teeth		4	4	4
Milling diameter	mm	25	20	20
Spec. cutting force	N/mm ²	1,910	1,910	1,910
Tapping (Ck45)				
Thread size	mm	M20×1.5	M20×1.5	M16×1.5
Spindle speed	rpm	318	318	397

	CTX beta 1250 TC 4A	CTX gamma TC
Performance data		
Power (40/100% DC), torque (40/100% DC)		
VDI 40, 12-station star turret with TRIFIX® 12×4,000 rpm 10/5 kW, 36/28 Nm	•	–
VDI 30, 16-station star turret with TRIFIX® 12×4,000 rpm 10/5 kW, 32/28 Nm	◦	–
VDI 40, 12-station (VDI 30, 16-station) star turret with TRIFIX® 12×4,000 rpm 10/8 kW, 28/22 Nm	–	◦
VDI 40, 12-station star turret with TRIFIX® DirectDrive, 12×10,000 rpm 14.2/10.9 kW, 34/26 Nm	◦	–
VDI 30, 16-station star turret with TRIFIX® DirectDrive, 16×10,000 rpm 13.4/10.9 kW, 32/26 Nm	◦	–

• Standard ◦ Option – not available

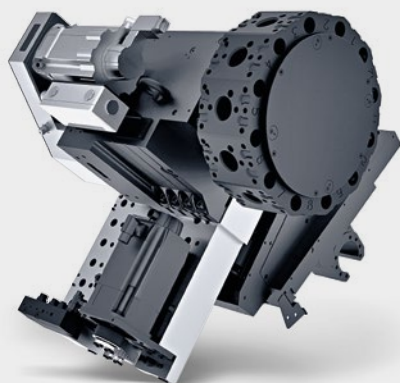



PRODUCTION TURNING WITH SECOND TOOL CARRIER

- + Lower turret with up to 16 driven tools
- + Shorter tooling times with TRIFIX® precision interface
- + DirectDrive* with 10,000 rpm for highest surface quality
- + Optional with Y-axis ± 40 mm**

*Available for CTX beta 1250 TC 4A

** Available for CTX beta 1250 TC 4A with DirectDrive turret

AUTOMATION CTX beta TC

Robo2Go 2nd generation - Flexible automation, programmed easily

- + Three versions for all demands: **Payload robot 10/20/35 kg**
- + Handling of **shaft parts** $\varnothing 25 - 150$ mm and **chuck parts** $\varnothing 25 - 170$ mm as standard
- + Modular gripper set: **Outside** and **Inside gripping** as standard
- + Customer-specific workpiece trays possible
- + **Stacking of workpieces**
- + **Optimal accessibility** to the machine
- + Parallel **use with bar loader** possible
- + Laser scanner for monitoring the fence-free safety zone
- + **Flexible setup** at multiple turning machines
- + Available for CTX beta 800 TC, CTX beta 1250 TC and CTX beta 1250 TC 4A*

*With optional chain magazine



Shaft parts tray



Stacking magazine



MACHINE, AUTOMATION AND CONTROL FROM A SINGLE SOURCE!

- + In the machine control **integrated operation via CELOS APP**
- + **New control** for dialogue-guided, intuitive operability
- + **No robot programming knowledges necessary**
- + **Multijob function:** Various jobs on one workpiece tray. Ideal for small and medium batch sizes
- + Creation of a process based on **predefined program modules**
- + Easy creation of individual workpiece trays
- + Home function for easy retraction and setup of the system



Intelligent workpiece handling for maximum productivity



Illustration: Design study

GX 60 T – FLEXIBLE AND EFFICIENT GANTRY LOADER

- + Loading and unloading of workpieces up to 60 kg
- + Integration into the machine control for easy programming and setup
- + Modular workpiece storage for chuck parts and shaft parts
- + Easy maintenance through optimized design
- + Available for all CTX gamma TC-machines

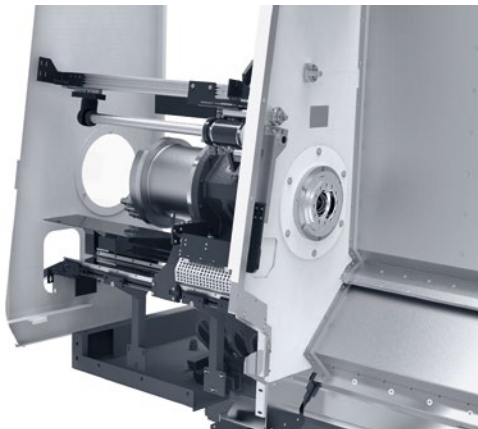

COMPLETE PACKAGE FOR BAR MACHINING

- + Workpieces up to $\varnothing 102 \times 600$ mm / 10 kg
- + Preparation for bar feed or bar loading magazine
- + Automatic workpiece pickup device for workpieces up to 6 kg and up to 200 mm
- + Conveyor belt for removal of workpieces from the machine
- + Simple programming via CELOS
- + Available for CTX beta 800/1250 TC/1250 TC 4A



CUSTOMER-SPECIFIC SOLUTIONS FOR YOUR WORKPIECE

- + Holistic solution: From planning and simulation to the handover of the ready-to-operate production line
- + Turnkey solution
- + Integration of related peripherals
- + Integrated additional functions: washing, measuring, engraving

CTX TC

Technological competence in all sectors



Mechanical engineering: Sprocket

Machine	CTX beta 800 TC
Material	Ck45
Workpiece dimensions	ø 180 × 80 mm
Machining time	11.5 min.
Highlight	High-performance turning, milling, drilling



Fluid / Hydraulics: Connecting flange

Machine	CTX beta 800 TC
Material	Ck45
Workpiece dimensions	ø 120 × 120 mm
Machining time	11.4 min.
Highlight	6-sided complete machining



Aerospace: Blade

Machine	CTX beta 800 TC
Material	1.4021
Workpiece dimensions	ø 61 × 260 mm
Machining time	29 min.
Highlight	5-axis simultaneous machining



Mechanical engineering: Rotor shaft

Machine	CTX beta 1250 TC
Material	Ck45
Workpiece dimensions	ø 120 × 300 mm
Machining time	19.2 min.
Highlight	6-sided complete machining



Energy: Clamping piece

Machine	CTX beta 800 TC
Material	GK-CuZn38Al (Copper-zinc alloy casting)
Workpiece dimensions	62 × 45 mm
Machining time	7.4 min.
Highlight	Pure milling, bar machining



Mechanical engineering: Gear hollow shaft

Machine	CTX beta 1250 TC
Material	Ck45
Workpiece dimensions	∅ 130 × 300 mm
Machining time	29 min.
Highlight	gearSKIVING



Aerospace: Adjusting spindle

Machine	CTX gamma 1250 TC
Material	Ck45
Workpiece dimensions	∅ 80 × 315 mm
Machining time	19.5 min.
Highlight	Multi-Threading Cycle



Aerospace: Connecting piece

Machine	CTX gamma 2000 TC
Material	Titanium
Workpiece dimensions	∅ 250 × 125 mm
Machining time	8 hours
Highlight	5-axis simultaneous machining High Performance Turning & Milling Profit Turning (Esprit)



Power engineering: Guide vane

Machine	CTX gamma 2000 TC
Material	X13Cr12Ni2W1V-5 (steel)
Workpiece dimensions	∅ 110 × 770 mm
Machining time	180 min.
Highlight	5-axis simultaneous machining

CTX TC

CELOS – From the idea to the finished product



SIEMENS with ShopTurn 3G

- + Dialog-guided programming with graphical support
- + 3D graphics including real-time simulation
- + New, clear screen design
- + Ample diagnosis for all drives

APP Selector: Central access to all available applications

ERGOline CONTROL WITH 21.5" MULTI-TOUCH SCREEN AND SIEMENS

Simple

Simple machine operation for all new high-tech machines from DMG MORI.

Consistent

Consistent administration, documentation and visualisation of order, process and machine data.

Compatible

Compatible with PPS and ERP systems.
 Can be networked with CAD/CAM products.
 Open to trendsetting CELOS APP extensions.



DMG MORI process chain – from the idea to the finished workpiece



CAD/CAM PROGRAMMING WITH SIEMENS NX CAM OR ESPRIT

- + Programming for single and multi-channel turning centres with main and counter spindle
- + Milling operations with the C-, Y- and B-axis, 2D, 3D and 5-axis simultaneous machining
- + Rotation routines for roughing, finishing, piercing, tapping and drilling
- + Multi-channel synchronisation
- + Program structure output (post-processor)

Real representation of the machining compartment with the DMG MORI Virtual Machine

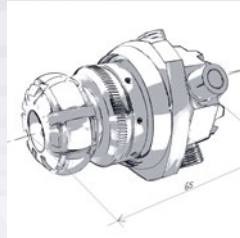

Idea
from the idea to the CAD model

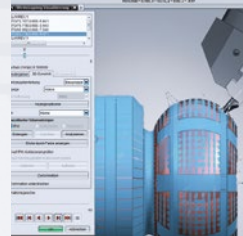

CAM programming
with NX CAM from SIEMENS or ESPRIT

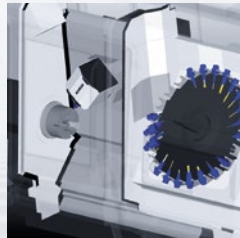

1 : 1 Simulation with the DMG MORI Virtual Machine



Production with DMG MORI machines

Simulation with DMG MORI Virtual Machine

- + Highest process reliability with collision and machining compartment control
- + Authentic machine model with exact work room representation
- + Comprehensive control of all program and production sequences in advance 1 : 1
- + Simulation of handwritten programs
- + ShopFloor programming
- + Real determination of job times due to integration of the PLC
- + Significant reduction of the setup and tooling time
- + Efficient production startup due to optimal preparation

DMG MORI TECHNOLOGY CYCLES

Exclusive technology cycles – Complex machining easily realised

DMG MORI exclusive technology cycles are genuine assistive systems for shopfloor programming that help boost productivity, improve safety and enhance the capability of machines.

- + Clear programming structure
- + Up to 60 % faster programming
- + Error reduction thanks to dialog-guided programming
- + Technology know-how saved in the program



AVAILABLE TECHNOLOGY CYCLES FOR CTX TC MACHINES:

Handling

- + Tool sorting cycle¹
- + Tailstock for turret²
- + Steady rest for turret²
- + Counter spindle tip³
- + Control of program status
- + Multitool
- + ATC 2.0 (Application Tuning Cycle)
- + Alternating speed
- + Retraction Cycle

¹ only with tool magazine

² only with lower turret

³ only in conjunction with counter spindle

Machining

- + 5-axis simultaneous machining
- + Multi threading 2.0
- + Polygon/oval turning
- + Gear Hobbing
- + gearSKIVING 2.0
- + DMG MORI gearMILL
- + Grinding
- + Interpolation turning
- + Eccentric machining
- + Y-Axis Parting
- + Keyway Broaching
- + crownHOBBING

Monitoring

- + Runtime monitor
- + MPC 2.0 – Machine Protection Control
- + Easy Tool Monitoring 2.0

Measuring

- + 3D quickSET

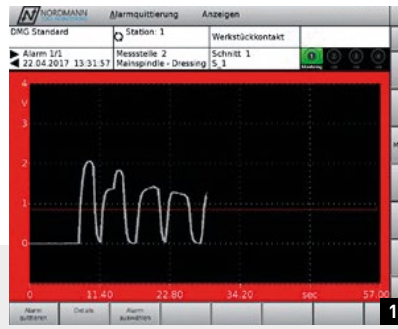

1: Acoustic emission sensor: Monitoring of the dressing process 2: Tool technology: Standardised grinding wheel holder with IKZ
 3: In-process measurement: Measurement repeat accuracy up to 0.8–1.0 µm (Marposs Micromar 8)

From 3 to 1: Technology integration grinding on Turn & Mill machines



COMPLETE MACHINING IN A NEW DIMENSION

- + Turning, milling and grinding on one machine
- + Higher shape and positional tolerances due to one single setup
- + Best possible shape and surface quality:
 - Ra: <math>< 0.2 \mu\text{m}</math>
 - Rz: <math>< 2.0 \mu\text{m}</math>
 - Roundness: <math>< 3 \mu\text{m}</math>
 - Quality 5 for $\varnothing > 30 \text{ mm}$
- + Dressing and grinding without air cuts thanks to use of acoustic emission sensor
- + Dialog-based dressing and grinding cycles for internal, external and face grinding (centric)
- + In-process measurement of the workpiece diameter due to measuring calliper on the steady rest slide

DRESSING AND GRINDING CYCLES

- + Intuitive, dialogue-guided programming
- + External and internal round grinding and face grinding
- + Grinding with straight / conical grinding discs and cup wheels
- + Vertical and horizontal dressing
- + Dressing tools using intuitive parameterisable input screens
- + Dressing with or without acoustic emission sensor

DMG MORI TECHNOLOGY CYCLES

Flexible and efficient gearing production on complete machining centres



gearSKIVING 2.0

- + Straight and helical external or internal spur gears and splines
- + Arrow teeth with tooth offset*
- + Ball-shaped toothing by means of the mathematical transformation of the 6th virtual axis*
- + Up to 8 times faster compared to shaping with quality up to DIN 7

* CTX TC with counter spindle



GEAR HOBBING

- + Up to 50% time saving thanks to programming of gear parameters via dialog inputs
- + Straight, oblique, curved gears and worm wheels
- + Maximised tool life by shifting the milling cutter
- + Achievable quality \leq DIN 7



Efficient complete machining:

- + Soft and hard machining on one machine
- + Quality check during operation

DMG MORI gearMILL

- + Cost-effective gear cutting on standard machines with standard tools
- + Flexible for different gear geometries
- + Gearing quality bevel gear DIN up to 5
- + Face gear DIN up to 6
- + In-process quality checks

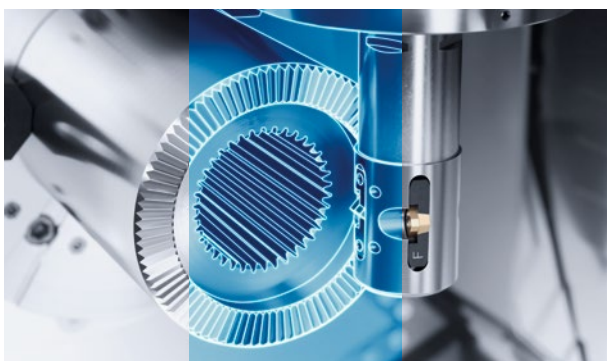

crownHOBBING

- + Production of hirth serrations by impact milling
- + Automatic calculation of the tool path movement
- + Position-oriented tooth pairings by determining the angular position of the toothing on the workpiece
- + Strong shortening of the process chain because no special machines are needed



5-AXIS SIMULTANEOUS MACHINING – INTELLIGENT MOVEMENT GUIDANCE FOR PERFECT SURFACES

- + Free form surfaces with 5-axis interpolation on the main and counter spindles
- + Turning and milling with interpolating B-axis
- + With ATC tuning for increased machine dynamics
- + Look-ahead function for continuous processing
- + High surface quality and transitions in combination with thermal compensation

ENERGY EFFICIENCY

Up to 34 % savings due to energy efficiency measures as standard

Calculation basis for production conditions

General information		
Machine utilisation	h/day	16
Working days/year	days/p. a.	250
Percentage of production	%	50
Percentage of operational readiness	%	40
Percentage of standby	%	10
Time slices in production		
Roughing	%	25
Mean output	%	25
Finishing	%	50

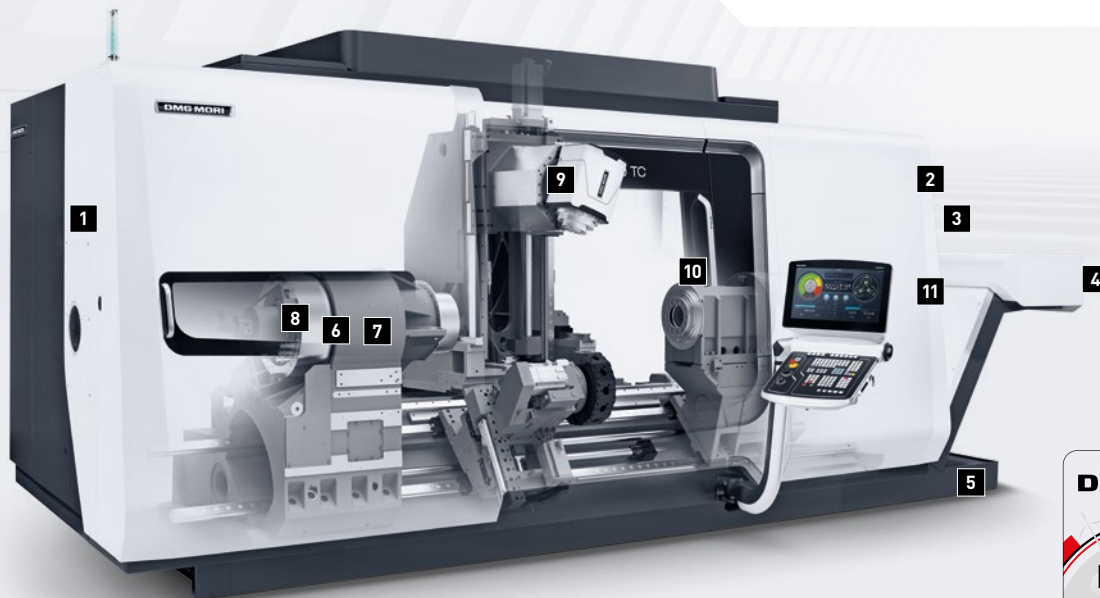

Energy efficient measures

- 1** Frequency-controlled hydraulic aggregate
- 2** Cooling unit with precision control
- 3** Regulated switch cabinet cooler
- 4** Timed chip conveyor
- 5** Regulated cooling lubricant pump
- 6** Energetic brake energy recovery system
- 7** DirectDrive with synchronous motor
- 8** Clamping cylinder with minimum leakage
- 9** Needs-based clamping cylinder
- 10** LED workspace lighting
- 11** DMG MORI AUTOshutdown for switchoff after program end

	Saving* [in %]	Current consumption [in kW/h]
Savings		
CTX beta 800 TC	28	37,103
CTX beta 1250 TC	27	41,333
CTX beta 1250 TC 4A	27	55,681
CTX beta 2000 TC	27	45,507
CTX gamma 1250 TC	32	54,566
CTX gamma 2000 TC	34	64,714
CTX gamma 3000 TC	30	76,585

*Basis for measurement: Previous model 2010 (CTX beta 800/1250 TC: 2009; CTX beta 1250 TC 4A: 2011)

	40%	60%	80%	100%
			CTX beta 800 TC 38,004 kWh/a consumption 28% saving	Comparable machine from 2009 (53,401 kWh/a)
			CTX beta 800 TC	Comparable machine (2009)
Energy consumption			38,004 kWh/a	53,401 kWh/a
Saving			15,397 kWh/a -28%	-



CTX beta 800 TC

60 kVA connected load
34 kW max. spindle power
8.9 kW medium spindle power



Design: FEM-optimized design with high static and low moving masses

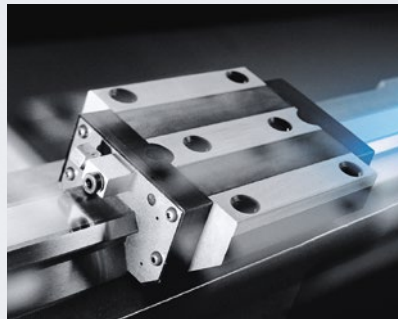

Linear guides: Low friction due to consistent use of roller bearing technology

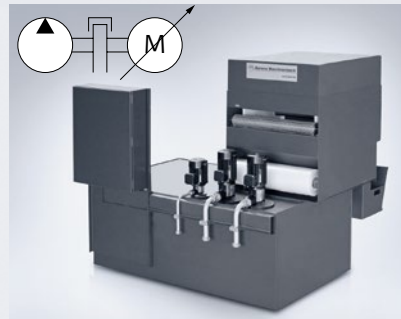

Servo technology/frequency control:
Frequency-controlled coolant and hydraulic pumps instead of fixed displacement pumps with regulator technology



Drives: Energy recovery during the braking phases of spindles and feed drives

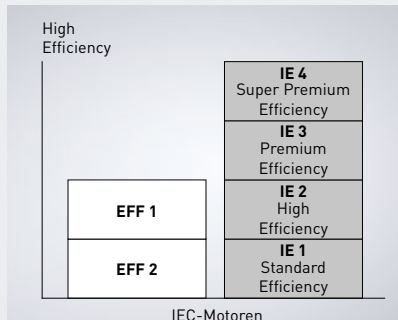

Motor: Use of the latest drive motors with up to 93% efficiency



Cooling: Inverter-controlled systems for demand-based cooling*

*Option

CTX TC

Performance diagrams and options

TURNING SPINDLES

ISM 52

6,000 rpm / 14.5 kW / 200 Nm (40 % DC)

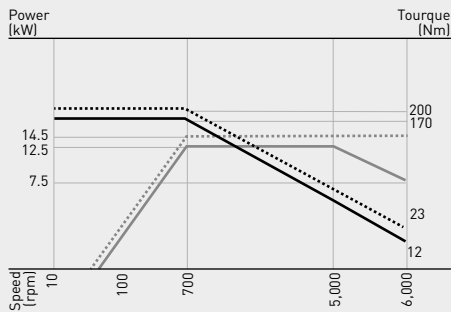

ISM 76

5,000 rpm / 32 kW / 360 Nm (40 % DC)

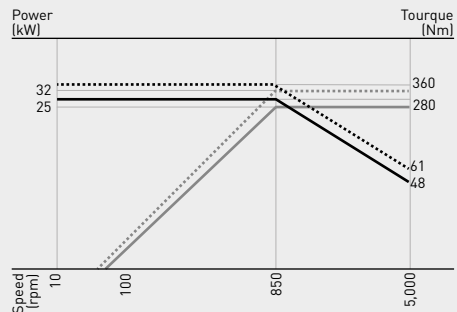

ISM 102

4,000 rpm / 40 kW / 700 Nm (40 % DC)

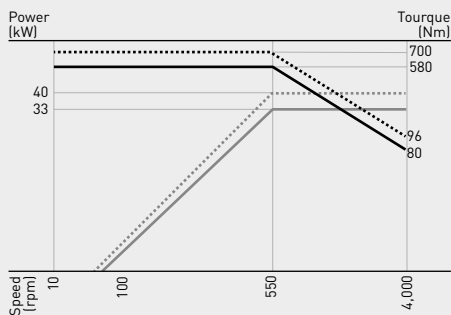

ISM 102 (CTX beta 1250 TC 4A)

4,000 rpm / 48 kW / 680 Nm (40 % DC)

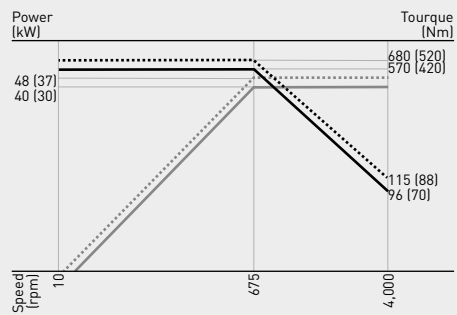

The values in brackets () relate to the counter spindle

ISM 102 PLUS / ISM 127

2,500 rpm / 52 kW / 2,200 Nm (40 % DC)

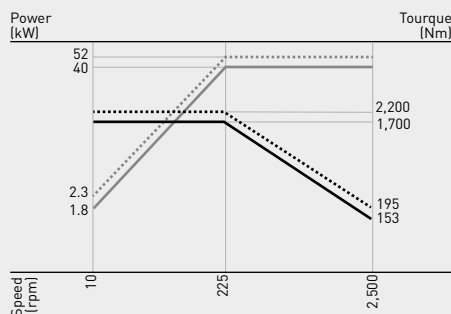

ISM 127 PLUS

2,000 rpm / 59 kW / 4,000 Nm (40 % DC)

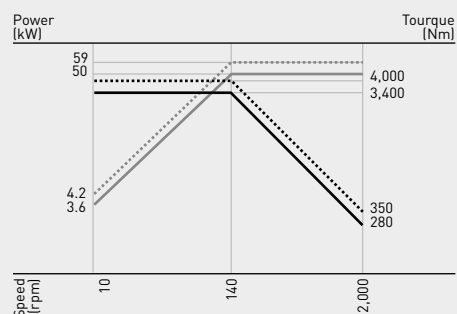

TURNING/MILLING SPINDLES

CTX beta TC

compactMASTER – Standard

12,000 rpm / 22.5 kW / 120 Nm (40 % DC)

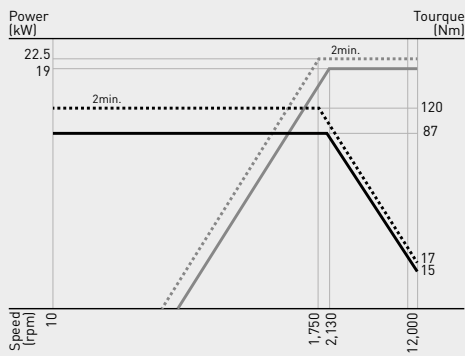

CTX beta / gamma TC

compactMASTER – Highspeed Option

20,000 rpm / 22.5 kW / 120 Nm (40 % DC)

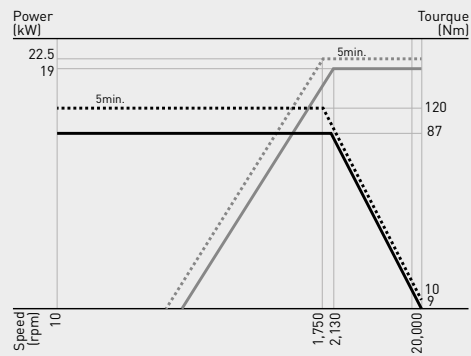

CTX gamma TC

compactMASTER – Standard

12,000 rpm / 36 kW / 220 Nm (40 % DC)

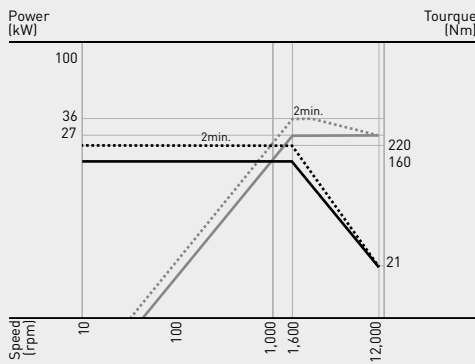

CTX gamma TC

compactMASTER – Option

10,000 rpm / 36 kW / 220 Nm (40 % DC)

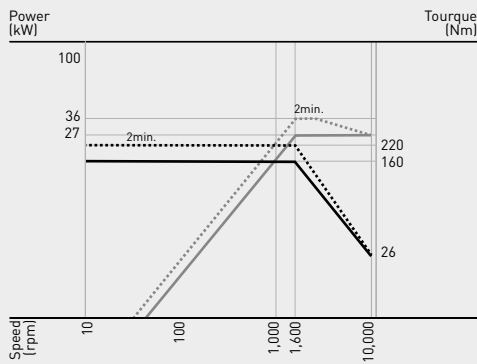

..... M [S3 40% DC] — M [S1 100% DC]
 P [S3 40% DC] — P [S1 100% DC]

CTX TC

Performance diagrams and options

TURRET

CTX beta 1250 TC 4A

Standard turret 12 × VDI 40

4,000 rpm / 10 kW / 36 Nm (40% DC)

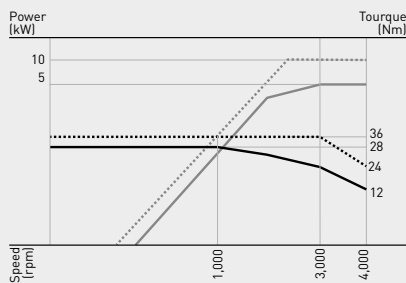

CTX beta 1250 TC 4A

Option DirectDrive turret 12 × VDI 40

10,000 rpm / 14.2 kW / 34 Nm (40% DC)

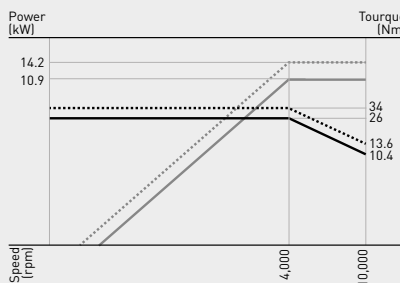

CTX gamma TC

Option turret 12 × VDI 40 (16 × VDI30)*

4,000 rpm / 10 kW / 28 Nm (40% DC)

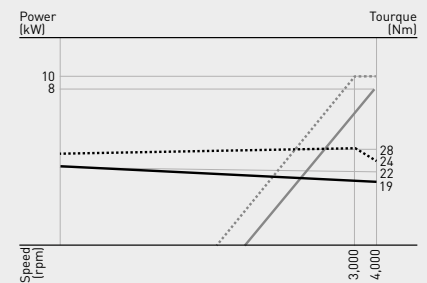

..... M (S3 40% DC) — M (S1 100% DC)
 P (S3 40% DC) — P (S1 100% DC)

TOOL MAGAZINES

	CTX beta 800/1250 TC	CTX beta 1250 TC 4A	CTX beta 2000 TC	CTX gamma TC
Tool magazine version				
Disk magazine, 24 stations (HSK-A63/Capto C6)	•	•	•	–
Disk magazine, 36 stations (HSK-A63/Capto C6)	–	–	–	•
Chain magazine, 48 stations (HSK-A63/Capto C6)	◦	–	◦	–
Chain magazine, 80 stations (HSK-A63/Capto C6)	◦	◦	–	◦
Chain magazine, 80 stations (HSK-A100/Capto C8)*	–	–	–	◦
Chain magazine, 100 stations (HSK-A63/Capto C6)	–	–	◦	–
Chain magazine, 120 stations (HSK-A63/Capto C6)	–	◦	–	◦
Chain magazine, 120 stations (HSK-A100/Capto C8)*	–	–	–	◦
Chain magazine, 180 stations (HSK-A63/HSK-A100/Capto C6/Capto C8)*	–	–	–	◦
Additional magazine for 3 oversized tools (HSK-A63/Capto C6)	–	–	◦	–
Additional magazine for 6 oversized tools (HSK-A63/HSK-A100/Capto C6/Capto C8)	–	–	–	◦

• Standard ◦ Option – not available *HSK-A100/Capto C8 only in connection with optional compactMASTER (10,000rpm)

CTX TC

Floor plans

CTX beta 800/1250 TC / 1250 TC 4A | CTX gamma 1250 TC – Schematic diagram

Front view

Top view

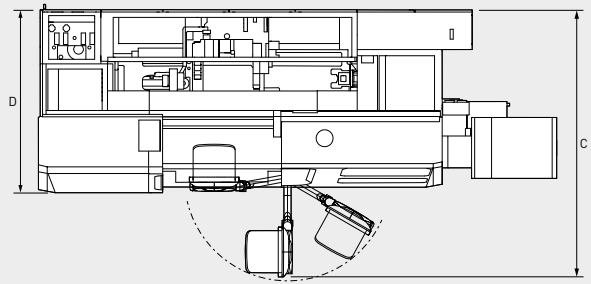
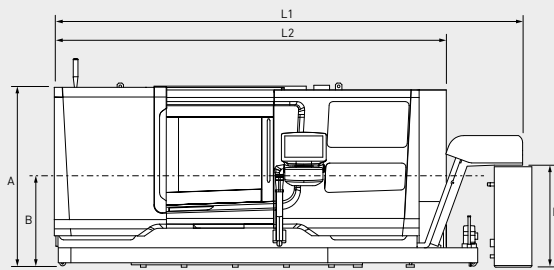

CTX beta 2000 TC | CTX gamma 2000/3000 TC – Schematic diagram

Front view

Top view

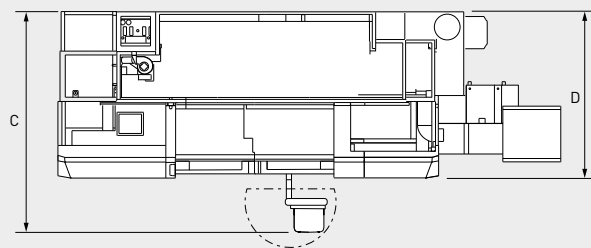
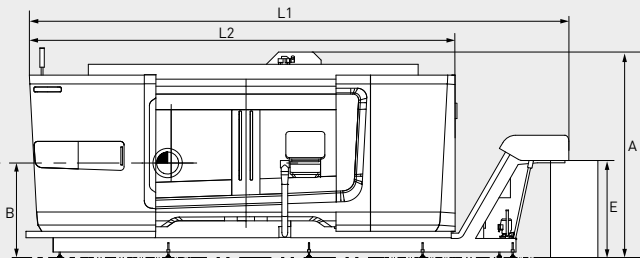

	A	B	C	D	E	L1	L2
Machine dimensions							
CTX beta 800 TC	2,247	1,050	2,910	2,065	1,269	4,957	4,100
CTX beta 1250 TC	2,247	1,040	3,061	2,065	1,269	5,854	4,900
CTX beta 1250 TC 4A	2,372	1,310	3,571	2,851	1,284	5,990	5,678
CTX beta 2000 TC	2,603	1,290	3,323	2,588	1,298	7,193	6,295
CTX gamma 1250 TC	2,805	1,290	3,627	2,608	1,234	7,074	5,577
CTX gamma 2000 TC	2,805	1,290	3,669	2,608	1,234	7,811	6,328
CTX gamma 3000 TC	2,805	1,290	3,669	2,608	1,234	8,840	8,067

Dimensions in mm

Highlights
Machine and technology
Automation
Applications
Control and technology cycles
Technical data
> Floor plans

CTX beta TC

Machining compartment

Machining compartment with one tool carrier

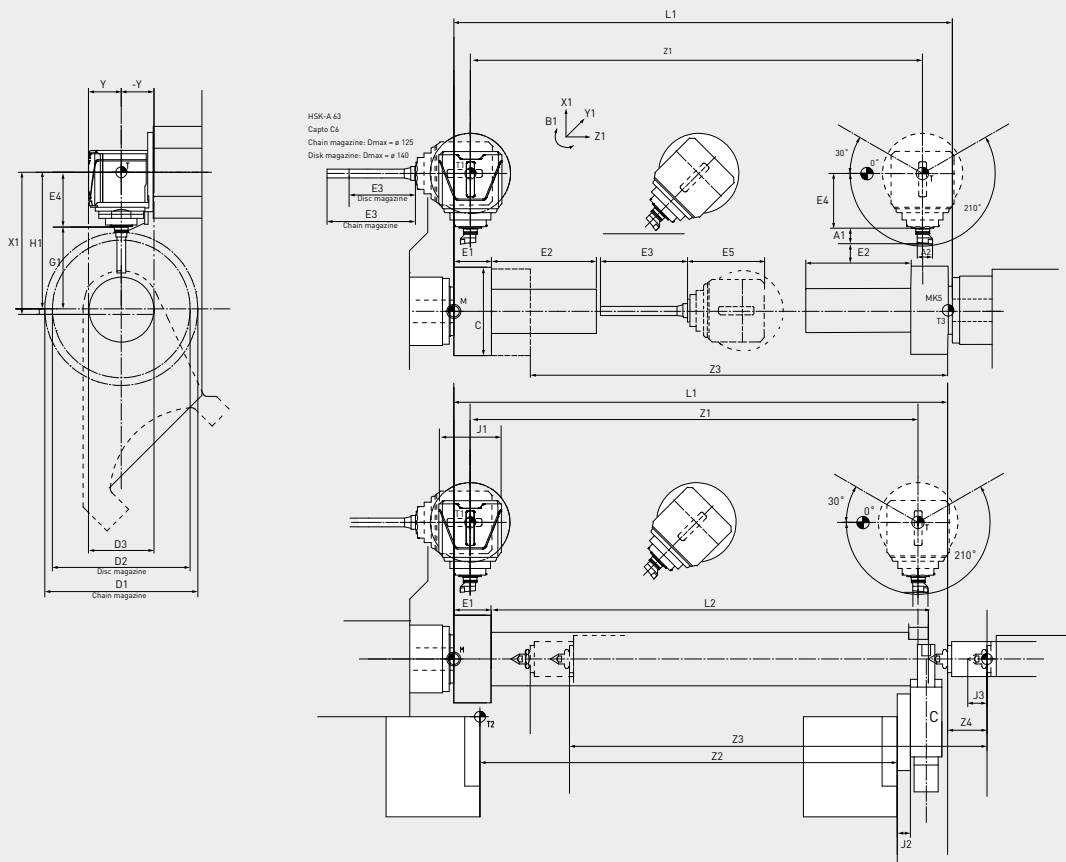

MACHINING COMPARTMENT DIMENSIONS

	CTX beta 800 TC	CTX beta 1250 TC	CTX beta 2000 TC		CTX beta 800 TC	CTX beta 1250 TC	CTX beta 2000 TC
A1	70	70	70	H1	470	480	625
A2	45	45	45	J1	286	286	286
B	±110°	±120°	±120°	J2	60	60	60
C	400	400	400	J3	87.5	87.5	87.5
D1	500	500	700	L1	1,020	1,470	2,260
D2	450	470	630	L2	1,078	1,473.5	2,240
D3	220	230	300	X1	480	490	650
E1	171.5	171.5	170	Y	±100	±125	±150
E2	150	350	480	Z1	800	1,200	2,050
E3	180	400	400	Z2	707	1,095	1,910
E4	175	175	175	Z3	800	1,200	1,910
E5	350	350	350	Z4	-	-	180
G1	295	305	375				

Machining compartment with two tool carriers

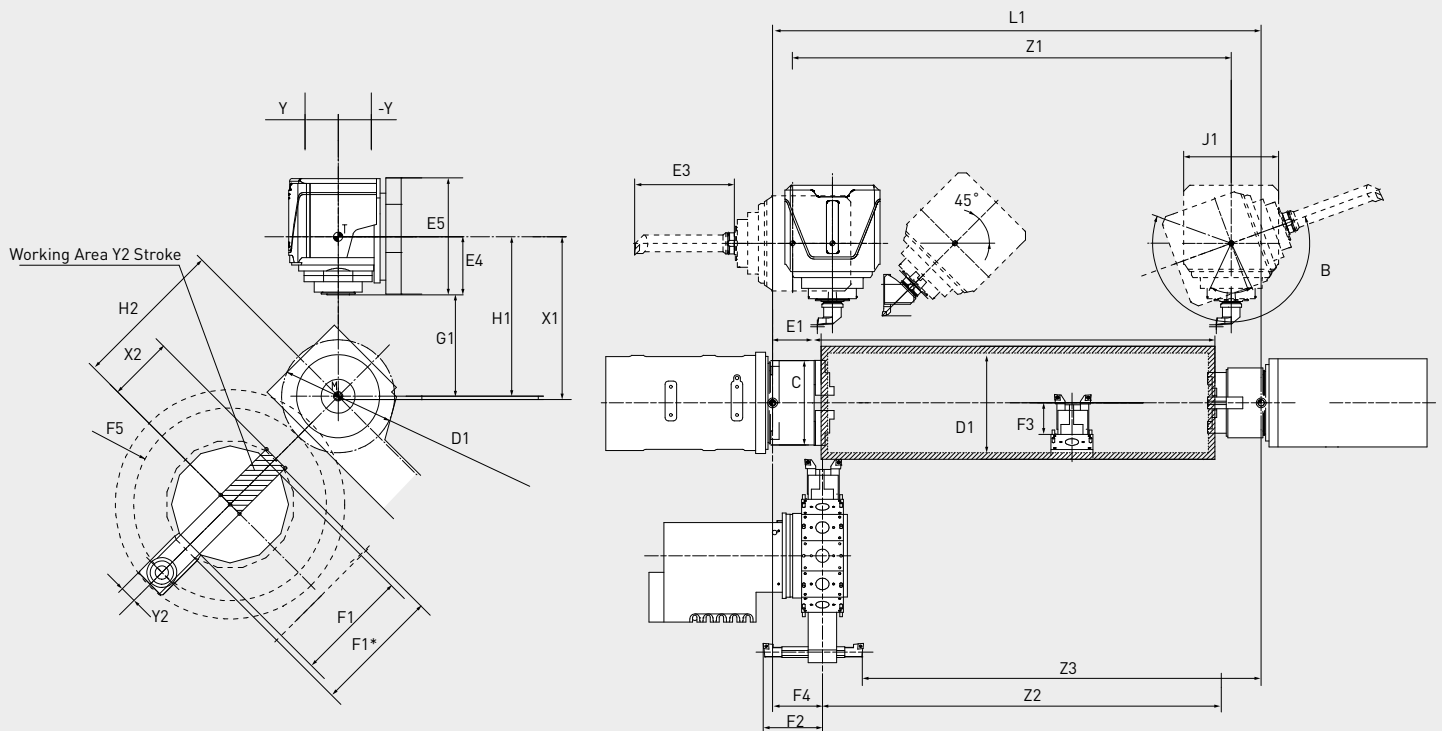

MACHINING COMPARTMENT DIMENSIONS

	CTX beta 1250 TC 4A	CTX beta 1250 TC 4A		CTX beta 1250 TC 4A
B	±110°	G1		305
C*	400	H1		480
D1	340	H2		460
E1	146	J1		286
E2	1,185	L1		1,470
E3	300	X1		490
E4	175	X2		195
E5	352.5	Y		±100
F1	340 [380]*	Y2**		80
F2	max. 178	Z1		1,200
F3	95	Z2		1,200
F4	150	Z3		1,200
F5	580			

* 340 mm: 12-fold turret, 380 mm: 16-fold turret

CTX gamma TC

Machining compartment

Machining compartment with one tool carrier

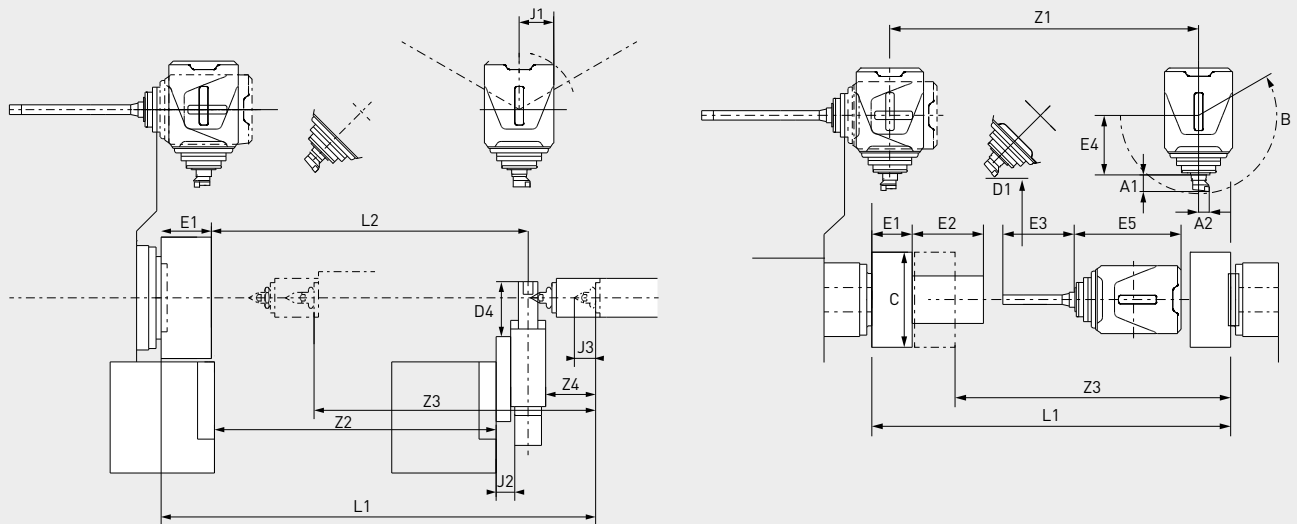

46

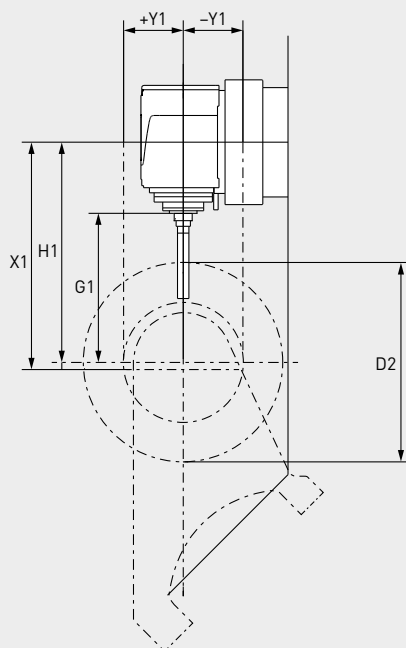

MACHINING COMPARTMENT DIMENSIONS

	CTX gamma 1250 TC	CTX gamma 2000 TC	CTX gamma 3000 TC
A1	70	70	70
A2	45	45	45
B	±120°	±120°	±120°
C	400	400	400
D1	630 (700)	630 (700)	630 (700)
D2	630 (700)	630 (700)	630 (700)
D3	420	420	420
D4	500	500	500
E1	170	170	170
E2	300	960	2,200
E3	300	400	400
E4	250 260***	250 260***	250 260***
E5	450 460	450 460	450 460
F1	SW 380	SW 380	SW 380
F2	220	220	220
F3	100	100	100
F4	180	180	180
F5	700	700	700

Machining compartment with two tool carriers

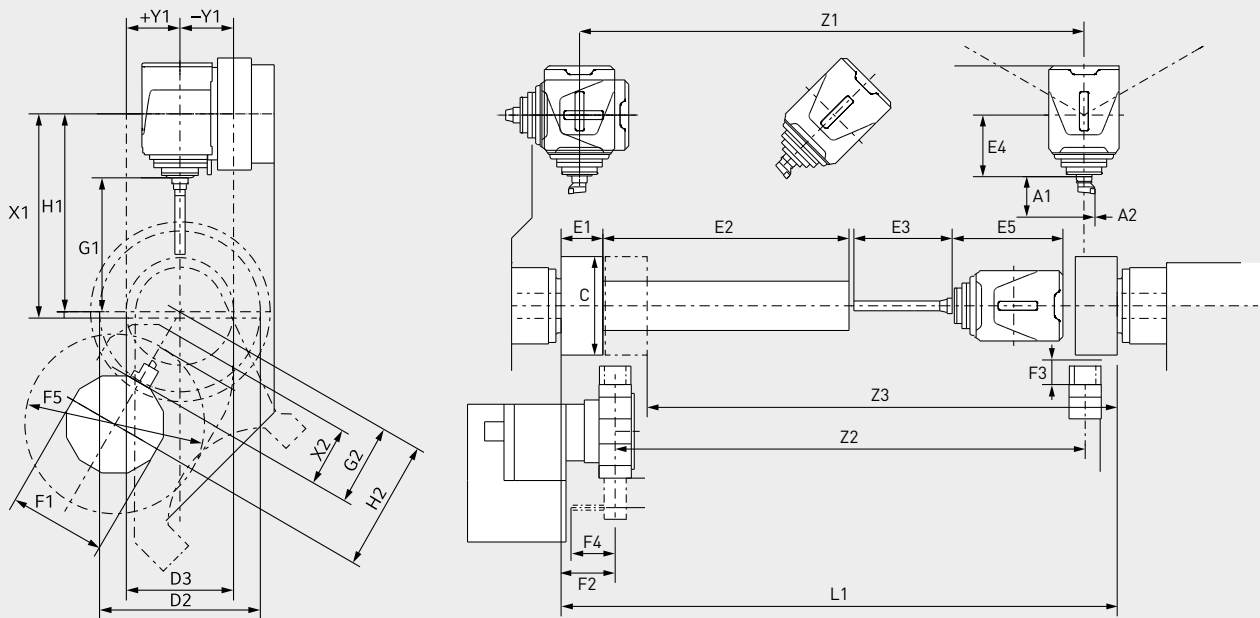

	CTX gamma 1250 TC	CTX gamma 2000 TC	CTX gamma 3000 TC
G1	525 515**	525 515**	525 515**
G2	320	320	320
H1	775	775	775
H2	510	510	510
J1	286	286	286
J2	60	60	60
J3	87.5	87.5	87.5
L1	1,790 / 1,510*	2,440 / 2,260*	3,380 / 3,260*
L2	1,300	2,000	2,950
X1	800	800	800
X2	320***	320***	320***
Y1	±210	±210	±210
Z1	1,300	2,050	3,050
Z2	1,160	1,910	2,850
Z3	1,160	1,910	2,850
Z4	180	180	180

* with tailstock / with counter spindle
 ** HSK-A63 / Capto C6 I HSK-A100 / Capto C8
 *** 245 mm in the range of Z2 0-220 mm

Highlights
Machine and technology
Automation
Applications
Control and technology cycles
Technical data

CTX TC

Technical data

		CTX beta 800 TC	CTX beta 1250 TC
Machining compartment			
Max. Swing diameter	mm	500	500
Max. Turning diameter (disk/chain magazine)	mm	450/500	470/500
Distance from main spindle to tailstock (without chuck)	mm	1,077.5	1,473.5
Distance from main spindle to counter spindle (without chuck)	mm	1,020	1,470
Max. turning length (machinable)	mm	750	1,200
Main spindle (standard)		ISM 76	ISM 76
Speed	rpm	5,000	5,000
Drive power/torque (40% DC)	kW/Nm	32/360	32/360
Spindle bearing – ϕ in the front bearing	mm	130	130
Draw tube – internal – diameter	mm	67 (77 ¹)	67 (77 ¹)
Spindle head (flat flange)/max. Chuck diameter ¹	mm	170 h5/315	170 h5/315
Counter spindle		ISM 52¹	ISM 52¹
Speed	rpm	6,000	6,000
Drive power/torque (40% DC)	kW/Nm	14.5/200	14.5/200
Spindle bearing – ϕ in the front bearing	mm	100	100
Draw tube – internal – diameter	mm	52	52
Spindle head (flat flange)/max. Chuck diameter ¹	mm	140h5/210	140h5/210
B-axis with turning-milling spindle (standard)			
Tool holder/Number of tool stations		HSK-A63/24	HSK-A63/24
Spindle speed	rpm	12,000	12,000
Drive power/torque (40% DC)	kW/Nm	22.5/120	22.5/120
Swivel range B-axis	°	± 110	± 120
Rapid traverse B-axis	rpm	70	70
Lower turret			
Number of driven tools/max. rotational speed	rpm	-	-
Drive power/torque (40% DC)	kW/Nm	-	-
Indexing time 30°	sec.	-	-
Top slide for B-axis			
X/Y/Z	mm	480 (+470/-10)/ $\pm 100/845$	490 (+480/-10)/ $\pm 125/1,300$
Rapid traverse X/Y/Z	m/min	30/40/40	40/40/50
Feed force X/Y/Z (S3 – 40%)	kN	10/7/10	10/7/10.3
Lower turret slide			
X/Z	mm	-	-
Rapid traverse speed X/Z	m/min	-	-
Feed force X/Y/Z (S3 – 40%)	kN	-	-
Slide for counter spindle			
Z	mm	800	1,200
Rapid traverse speed Z	m/min	40	30
Feed force Z (S3 – 40% DC)	kN	10	10
Tailstock			
Stroke (hydraulic)	mm	800	1,200
Centre sleeve force	kN	8	14
Tailstock centre	MK	5	5
Machine			
Space requirement machine incl. chip conveyor	m ²	10.2	12.1
Drop height chip conveyor	mm	1,270	1,270
Machine height	mm	2,300	2,300
Machine weight	kg	10,000	15,000

1: Option 2: Turning diameter with turret 3: With chain magazine

CTX beta 1250 TC 4A	CTX beta 2000 TC	CTX gamma 1250 TC	CTX gamma 2000 TC	CTX gamma 3000 TC
700	630/700 ³	700	700	700
500 (340) ²	630/700	630/700	630/700	630/700
-	2,440	1,790	2,440	3,380
1,470	2,260	1,510	2,260	3,260
1,185	2,000	1,250	2,000	3,000
ISM 76	ISM 76	ISM 102	ISM 102	ISM 127
5,000	5,000	4,000	4,000	2,500
32/360	32/360	40/700	40/700	52/2,200
130	130	160	160	200
67 (77 ¹)	67 (77 ¹)	104	104	127
170 h5/315	170 h5/315	220 h5/400	220 h5/400	A15/630
ISM 76	ISM76¹	ISM 76¹	ISM 76¹	ISM 102¹
5,000	5,000	5,000	5,000	4,000
32/360	32/360	32/360	32/360	40/700
130	130	130	130	160
67	67	67	67	104
170h5/315	170h5/315	170h5/315	170h5/315	220h5/400
HSK-A63/24	HSK-A63/24	HSK-A63/36	HSK-A63/36	HSK-A63/36
12,000	12,000	12,000	12,000	12,000
22.5/120	22.5/120	36/220	36/220	36/220
±110	±120	±120	±120	±120
70	100	100	100	100
12×VDI 40	-	12×VDI 40¹	12×VDI 40¹	12×VDI 40¹
12/4,000	-	12/4,000	12/4,000	12/4,000
10/36	-	10/28	10/28	10/28
0.4	-	0.44	0.44	0.44
490 (+480/-10)/±100/1,200	490 (+480/-10)/±150/2,050	800/±210/1,300	800/±210/2,050	800/±210/3,050
30/30/45	40/40/30	50/50/50 (70 ²)	50/50/50 (70 ²)	50/50/40
7/7/13	12.5/11/16	11.5/12/18 (10.4 ²)	11.5/12/18 (10.4 ²)	11.5/12/20
195/80/1,200	-	235/-/1,160	235/-/1,910	235/-/3,050
30/45	-	30/40	30/40	30/30
12/13	-	7.5/14	7.5/14	7.5/12
1,200	1,910	1,160	1,910	2,850
45	30	40	40	30
13	16	14	14	28
-	1,200	NC-axis and hydraulically movable steady rest		
-	18	17	17	22
-	5	5	5	5
17.1	18.6	18.4	20.4	23.0
1,270	1,250	1,234	1,234	1,234
2,419	2,380	2,805	2,805	2,805
16,000	22,000	18,500	24,000	30,000

Highlights
Machine and technology
Automation
Applications
Control and technology cycles
Technical data
> Options

CTX beta TC

Options

	CTX beta 800 TC	CTX beta 1250 TC	CTX beta 1250 TC 4A	CTX beta 2000 TC
Machine options				
Linear drive in the Z1-axis (slide of the B-axis)	–	○	–	–
Differential pressure clamping for the main spindle and/or counter spindle	○	○	○	○
Disk magazine 24 stations	●	●	●	●
Chain magazine 48 stations	○	○	–	○
Chain magazine 80 stations	○	○	○	–
Chain magazine 100 stations	–	–	–	○
Chain magazine 120 stations	–	–	○	–
Measuring / monitoring				
Tool measuring device for turning and milling tools	○	○	○	○
Mechanical drill breakage monitoring	○	○	○	○
In-process workpiece measurement via measuring probe	○	○	○	○
Bar machining / automation				
Package bar machining with workpiece pickup device, hydraulic partial hollow clamping device, signal light 4-colour and connection for bar feed or bar loading magazine	○	○	○	–
Bar loading magazines for max. bar length 1.2 to 3.2 m (machine-dependent)	○	○	○	–
Automation interface	○	○	○	○
Shaft machining				
Tailstock function for counter spindle	○	○	○	○
Steady rest slide, automatic positioning	○	○	–	–
Steady rest slide, NC controlled	–	–	–	○
Steady rest clamping range 8 – 101 mm	○	○	○	○
Steady rest clamping range 20 – 165 mm	○	○	–	○
Steady rest clamping range 30 – 245 mm	–	–	–	○
Steady rest clamping range 85 – 350 mm	–	–	–	○
Steady rest quick-change system	○	○	–	○
Clamping device for main spindle				
Chuck up to ø 210 mm incl. attachments and chuck jaws	○	○	○	○
Chuck up to ø 250 mm incl. attachments and chuck jaws	○	○	○	○
Chuck up to ø 315 mm incl. attachments and chuck jaws	○	○	○	○
Chuck up to ø 400 mm incl. attachments and chuck jaws	○	○	○	○
Clamping device for counter spindle				
Chuck up to ø 170 mm incl. attachments and chuck jaws	○	○	–	–
Chuck up to ø 210 mm incl. attachments and chuck jaws	○	○	○	○
Chuck up to ø 250 mm incl. attachments and chuck jaws	–	○	○	○
Chuck up to ø 315 mm incl. attachments and chuck jaws	–	–	○	○
Chuck up to ø 400 mm incl. attachments and chuck jaws	–	–	○	○
Coolant and chip conveyor				
Chip conveyor	○	○	○	○
Reinforced coolant pump, 12 bar, 23 l/min	○	○	–	○
8/20 bar internal coolant supply, 600 l and 40 µm paper band filter	○	○	○	○
8/20 bar internal coolant supply, 980 l and 40 µm paper band filter	○	○	○	○
8/20 bar internal coolant supply, 980 l, 40 µm paper band filter and cooling unit	○	○	○	○
8/20/80 bar internal coolant supply, 980 l, 40 µm paper band filter and cooling unit	○	○	○	○
Aluminium package in connection with paper band filter	○	○	○	○
Oil mist extraction system	○	○	○	○
Other				
Machine adjustment for increased ambient temperatures (tropical package)	○	○	○	○

● Standard ○ Option

Options

	CTX gamma 1250 TC	CTX gamma 2000 TC	CTX gamma 3000 TC
Machine options			
Linear drive in the Z1-axis (slide of the B-axis)	○	○	–
Counter spindle	○	○	○
Differential pressure clamping for the main spindle and/or counter spindle	○	○	○
Disk magazine 36 stations	●	●	●
Chain magazine 80 stations	○	○	○
Chain magazine 120 stations	○	○	○
Chain magazine 180 stations	○	○	○
Additional magazine for 6 oversized tools (up to 700 mm length up to ø200 mm)	○	○	○
Second tool carrier as 12-fold turret with driven tools	○	○	○
Linear scales in X1/Y1/Z1	●	●	●
Linear scales in X2/Z2 turret slides	○	○	○
Measuring/monitoring			
Tool measuring device for turning and milling tools	○	○	○
Mechanical drill breakage monitoring	○	○	○
In-process workpiece measurement via measuring probe	○	○	○
Automation			
Preparation for external handling with robot interface, Profibus standard	○	○	○
Shaft machining			
Tailstock function for counter spindle	○	○	○
Sleeve for tailstock with 180 mm stroke (hydraulic)	●	●	●
Steady rest slide, NC-controlled, steady rest clamping range up to 460 mm	○	○	○
Steady rest quick-change system	○	○	○
Clamping device for main spindle			
Chuck up to ø250 mm incl. attachments and chuck jaws	○	○	–
Chuck up to ø315 mm incl. attachments and chuck jaws	○	○	–
Chuck up to ø400 mm incl. attachments and chuck jaws	○	○	○
Chuck up to ø500 mm incl. attachments and chuck jaws	○	○	○
Chuck up to ø630 mm incl. attachments and chuck jaws	–	–	○
Clamping device for counter spindle			
Chuck up to ø210 mm incl. attachments and chuck jaws	○	○	–
Chuck up to ø250 mm incl. attachments and chuck jaws	○	○	–
Chuck up to ø315 mm incl. attachments and chuck jaws	○	○	○
Chuck up to ø400 mm incl. attachments and chuck jaws	○	○	○
Chuck up to ø500 mm incl. attachments and chuck jaws	○	○	○
Chuck up to ø630 mm incl. attachments and chuck jaws	–	–	○
Coolant and chip conveyor			
Chip conveyor	○	○	○
8/20 bar internal coolant supply, 600 l and 40 µm paper band filter	○	○	○
8/20 bar internal coolant supply, 980 l and 40 µm paper band filter	○	○	○
8/20 bar internal coolant supply, 980 l, 40 µm paper band filter and cooling unit	○	○	○
8/20/80 bar internal coolant supply, 980 l, 40 µm paper band filter and cooling unit	○	○	○
8/20 bar internal coolant supply, frequency-controlled, 600 l and 40 µm paper band filter	○	○	○
8/20 bar internal coolant supply, frequency-controlled, 980 l and 40 µm paper band filter	○	○	○
8/20/80 bar internal coolant supply, frequency-controlled, 980 l, 40 µm paper band filter and cooling unit	○	○	○
Aluminium package in connection with paper band filter	○	○	○
Oil mist extraction system	○	○	○
Other			
Machine adjustment for increased ambient temperatures (tropical package)	○	○	○

● Standard ○ Option



Available for you around the clock:
service-hotline.dmgmori.com

Customer First – Our service promise!

“We have good news for you: Our service and spare parts prices have been completely revised. With our service commitments, we want to meet your high demands with the highest service quality.”

Please contact us – your sales and service team is at your disposal!

Top quality at fair prices. **It's a promise!**



Best Price Guarantee for Original Spare Parts. Should you get a spare part offered by us at least 20% cheaper elsewhere, we will refund the price difference up to 100%*.



Spindle service at best prices. The highest level of competence from the manufacturer at new and attractive prices – DMG MORI spindle service!



Up to 50% lower service costs. New Flat Call-Out Rate – without travel expenses or any additional costs!



Our protective shield for your productivity. Reduced operating costs, highest machine availability and maximum precision – DMG MORI Service *Plus!*



* All information and price advantages for Customer First are available at: customer-first.dmgmori.com